

Swing Check Valve with Bottom or Side Mounted Oil Cushion

Operation, Maintenance and Installation Manual

INTRODUCTION.....	2
RECEIVING AND STORAGE.....	2
VALVE CONSTRUCTION.....	3
DESCRIPTION OF OPERATION.....	3
INSTALLATION.....	5
VALVE START-UP PROCEDURE.....	6
TROUBLESHOOTING.....	7
DISASSEMBLY.....	7
RE-ASSEMBLY.....	13
PARTS AND SERVICE.....	14
WARRANTY.....	15



Stayflow VALVE AND MANUFACTURING CORP.

2323 W. Hubbard Street • Chicago IL 60612
Phone: 312-428-4750 • Stayflowproducts.com

STAYFLOW'S SWING CHECK VALVE OPERATION, MAINTENANCE AND INSTALLATION

INTRODUCTION

Stayflow's Swing Check Valve has been designed to give many years of trouble free operation. All parts are inspected prior to final assembly to insure complete interchangeability of parts. After assembly, each valve receives a hydrostatic seat test, using a pressure equal to the valves rated working pressure and a hydrostatic shell test, using a pressure equal to the hydrostatic shell test pressure outlined in AWWA C508 for the valve's flange class. The valves are designed to meet AWWA C508 with a cold working pressure (CWP) rating of 200 psi for 8 to 12 in. valves and 150 psi for 14 in. and larger valves..

This manual will provide you with the information needed to properly install and maintain the valve and to ensure a long service life. The valve is opened by the fluid flow in one direction and closes automatically to prevent flow in the reverse direction.

The optional oil dashpots may be mounted on the valve to allow for better control of surges and check valve slam.

Optional Limit Switches may be mounted on the valve to provide local and remote position indication.

The valve is capable of handling a wide range of fluids including flows containing suspended solids. The size, flow direction, maximum working pressure, and model no. are stamped on the nameplate for reference.

CAUTION

Do not use valve for line testing at pressures higher than nameplate rating or damage to valve may occur.

The "Maximum Working Pressure" is the nonshock pressure rating of the valve at 150°F. The valve is not intended as an isolation valve for line testing above the valve rating.

RECEIVING AND STORAGE

Inspect valves upon receipt for damage in shipment. Unload all valves carefully to the ground

without dropping. Valves should remain crated, clean and dry until installed to prevent weather related damage. When lifting the valve for installation, make sure that lifting chains, slings or straps are not attached to or allowed to come in contact with the seat areas, hinge pin, lever arm or the side mounted oil cushion assembly. Use hoist rings or lifting eyebolts in cover lifting tapped holes or use hoist rings through the flange holes on large valves.

WARNING

Use caution if using threaded holes in cover for lifting the valve. All three eye bolts should share the entire weight directly and equally.

Use of additional slings and/or straps is recommended for safety and ease of orientation during installation.

Table 1. Cover Lifting Eye Bolts

Valve Size	Lifting Eye Bolt	Valve Size	Lifting Eye Bolt
14"	M14	30"	M24
16"	M16	36"	M24
18"	M20	42"	M30
20"	M20	48"	M30
24"	M20		

Do not rest the weight of the valve on the hinge pin, bottom cushion, or the side mounted oil cushion assembly.

This precision equipment must remain crated, clean and dry until installed; to prevent weather related damage to the valve or to the pneumatic cylinder. Improper storage and installation procedures will void warranty.

For long term storage greater than six months, the rubber surfaces of the disc should be coated with a thin film of FDA approved grease. Do not expose disc to sunlight or ozone for any extended period.

STAYFLOW'S SWING CHECK VALVE OPERATION, MAINTENANCE AND INSTALLATION

VALVE CONSTRUCTION

The Swing Check Valve housing consists of a body section having integrally cast inlet and outlet flanges. The top portion of the body has a large integrally cast flanged access port, to which the top access cover is bolted. The size of this access port permits full access to the disc and seat components for maintenance or replacement.

The flow area through the body inlet, body seat ring and the body outlet is equal to 100% of the nominal inside area of the standard pipe. The center portion of the body is expanded to allow for the area that is occupied by the disc and because of the expanded area thru the center of the valve, the disc at 20 to 25 degrees open reaches a full flow area.

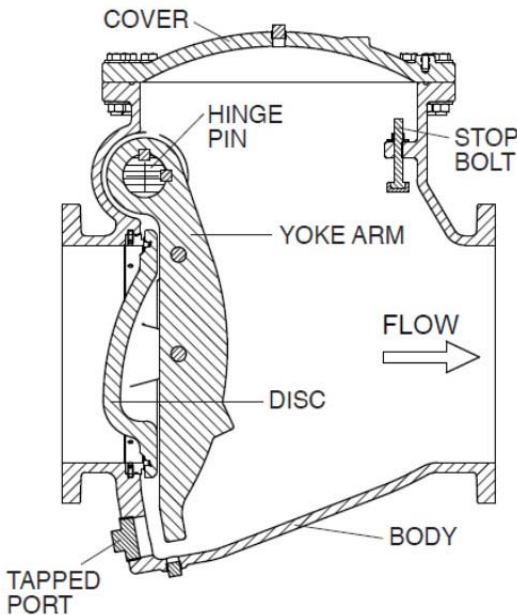

FIGURE 1. SWING CHECK VALVE

The body has two eccentrically located hinge pin trunnions that contain the hinge bushings and hinge packing. A continuous stainless steel hinge pin passes through the bushings and the disc yoke arm. The disc yoke arm is keyed to the hinge to lock them together rotationally. The disc is attached to the disc arm with two stainless steel pins, making the disc and disc yoke arm a solid assembly. The metal or resilient disc seal ring fits into a recessed register in the face of the disc and is captured and retained by a large circular retaining ring or segments and stainless steel screws. The resilient disc seal has O-ring type sealing beads that provide low pressure sealing when it contacts the stainless steel seat

ring, located in a machined register in the body. The seat ring has a groove on its outside diameter, which accepts an O-ring, that creates a seal between the interface of the inside diameter of the body register and the outside diameter of the seat ring.

The stainless steel or aluminum bronze body seat ring is threaded into the body in 8" through 12" sizes and retained to the body with stainless steel set screws that engage a groove within the body seat register in larger sizes. The exterior portion of the body has a machined mounting pad on each side of the valve for the mounting of side-mounted oil cushions.

The counterweight arm assembly is keyed to the extended portion of the pivot shaft. The counterweight arm assembly has additional keyways to allow for multiple mounting positions such as horizontal or about 30° below when closed. The counterweights are located on the counterweight arm and are secured to the lever with a bolt.

The body and the top cover are provided with plugged ports. The body port serves as a drain port and the top cover's port serves as a connection point for an automatic air release valve or as a vent port. A drain valve may also be connected to the bottom body port.

A large tapped port is provided under the valve seat for installation of the bottom-mounted oil dashpot when specified.

DESCRIPTION OF OPERATION

The valve is designed to prevent reverse flow automatically. During system flow conditions, the movement of the fluid forces the disc to the open position allowing 100% un-restricted flow area through the valve. Under reverse flow conditions, the disc automatically returns to the closed position to prevent reverse flow.

Upon pump start-up the forward flow of the water will start to rotate the disc about the hinge until the disc contacts the stop bolt in the valve body. The disc rotates through a 60 to 70 degree arc from the closed to the fully open position. On pump shut down the forward velocity of the water will start to diminish, as the forward velocity of the water is further reduced, the disc will start its travel to the closed position. When the forward velocity

STAYFLOW'S SWING CHECK VALVE OPERATION, MAINTENANCE AND INSTALLATION

of the water reaches zero, the disc has moved to the closed position and the reversal of the flow is checked. Under these ideal hydraulic conditions the valve should close without water hammer. However, ideal hydraulic conditions are not always predictable and the potential for water hammer exists. If the reversal of flow happens before the disc has a chance to react to the diminishing forward velocity of the water, the disc will be driven to the closed position by the rapid flow reversal. Depending on how fast the reversal of flow takes place, a water hammer of different magnitudes may develop.

The valve is equipped with an adjustable lever and weight, an optional bottom-mounted oil cushion, or an optional side-mounted oil cushion. These assemblies and adjustments may be used to vary the valve's closing operation in order to reduce the magnitude of the closing water hammer.

The bottom-mounted oil cushion is mounted into a tapped port in the bottom of the valve near the seat. The oil cushion has a short snubber rod which allows the disc to close rapidly to the 90% closed position. The last 10% of closed travel is then controlled by the oil flow through a flow control valve mounted on the high pressure hydraulic cylinder. An air/oil tank is provided to provide volume for excess oil from the cylinder.

The side-mounted oil cushion controls the speed of closure in two stages: 1) as the check valve closes, oil from the bottom port of the high pressure cylinders is controlled by a flow control valve, typically in 2-5 seconds and 2) during the last 10% of travel, an internal cushion in the cylinder controls the last 10% of travel in 1-3 seconds. Larger sizes have an oil cushion on both sides of the valve, see the general arrangement drawing provided with the valve. An air/oil tank is provided to provide volume for excess oil from the cylinder.

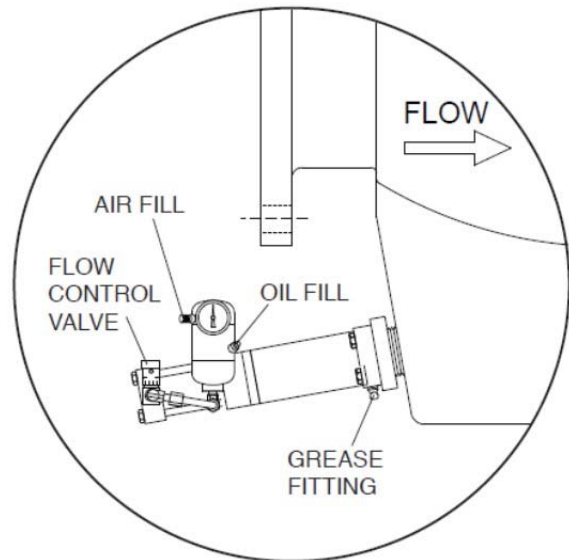

FIGURE 2. BOTTOM-MOUNTED OIL CUSHION

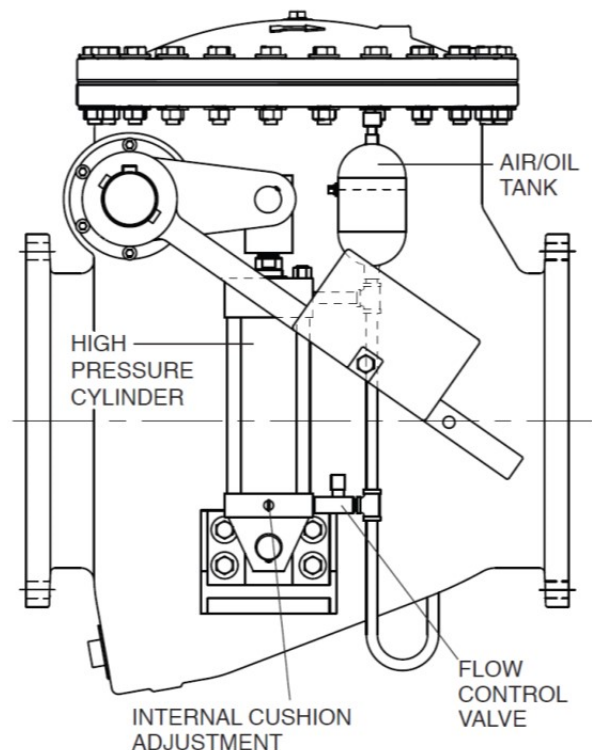

FIGURE 3. SIDE-MOUNTED OIL CUSHION

STAYFLOW'S SWING CHECK VALVE OPERATION, MAINTENANCE AND INSTALLATION

INSTALLATION

The swing check valve can only be used for horizontal flow or vertical flow-up applications. The valve must be in a laminar flow region of the piping system. Avoid locating the valve immediately downstream of a pipe elbow or in a cavitation zone because the turbulence in these regions will cause excessive disc motion and will result in premature wear.

For horizontal flow applications the valve must be installed with both of the pivot trunnions located above the horizontal center-line of the valve and the common center-line of the hinge trunnions must be level to the horizontal plane of the valve. For vertical flow up applications the counterweight arm should be in the horizontal or about 30° below horizontal position when the valve is in the closed position. The counterweight arm has multiple keyways to allow for mounting in several orientations.

Before installing the valve in the space provided, check to make sure that the pump discharge piping is free of foreign objects such as lumber, tools, rocks, etc., which can damage the swing check valve when it is placed in service.

When lifting the valve for installation, make sure that lifting chains or straps are not attached to or allowed to come in contact with the hinge pin, counterweight arm or the side-mounted oil cushion assembly. Also do not allow the weight of the valve to rest on the hinge pin, counterweight arm or the side or bottom mounted oil cushion assembly.

Each valve is provided with a flow arrow integrally cast on the valve cover. The flow arrow must point in the direction the water will flow, when the system is operating.

AWWA C508 swing check valves are furnished with flat faced flanges and should only be mated to a flat faced companion flange. A full faced or ring gasket, that has been lubricated with a gasket joint compound, must be installed between the valve's flange and the companion flange to effect a seal. Flange bolting shall be in accordance with ANSI B16.1 Section 5.2 for cast iron bodies and ANSI B16.42 for ductile iron bodies. Note: Stayflow does not recommend the use of high strength flange bolting with these valves.

Before installing the flange bolting, the valve and the adjacent piping must be supported and aligned to prevent cantilevered stress being transferred to the valve's flanges when installing the flange bolts or studs.

Apply a thread lubricant to the flange bolt threads and install the flange bolts and nuts around the flange. Once all the flange bolts or studs are inserted around the flange bolt circle, tighten them hand tight.

Recommended flange bolt lubricated target torque values for use with resilient gaskets (75 durometer) are given in Table 1. If leakage occurs, allow gaskets to absorb system fluid and check torque and leakage after 24 hours. Do not exceed the bolt rating, the maximum torque of Table 1, compress to more than the gasket manufacturer's thickness recommendation or extrude gasket.

Table 2. Flange Bolt Target Torque			
Valve Size (in)	Bolt Dia (in)	Recom. Torque (ft-lbs)	Maximum Torque (ft-lbs)
8"	3/4	30	150
10-12"	7/8	45	205
14-16"	1	80	300
18"-20"	1 1/8	100	425
24"-30"	1 1/4	150	600
36"-42"	1 1/2	300	900
48"	1 1/2	300	1000

The target torque for flange bolting is based on the flange construction, system pressure, system temperature, and the gasket material. The valve flange construction is per ASME B16.1 Class 125 (cast iron bodies) or ASME B16.42 Class 150 (ductile iron bodies). The gasket material and design is often the limiting factor for the flange bolt target torque and should best be obtained from the gasket manufacturer. Note: Flange joint leakage can be caused by exceeding the recommended target torque as well as inadequate or non-uniform bolt torque.

The flange bolt torque should be applied in several graduated steps using the cross-over bolt

STAYFLOW'S SWING CHECK VALVE OPERATION, MAINTENANCE AND INSTALLATION

tightening method to load the bolts evenly to eliminate concentrated stresses which could fracture or crack the valve's flange. See ASME PCC-1-2010 for details of the cross-over bolt tightening sequence and torque methods. Note that the target torque values provided in ASME PCC-1-2010 are based on the ANSI/ASME steel flange pressure and temperature ratings which exceed those of AWWA and are, therefore, often higher than appropriate for AWWA rated iron valves and flanges.

CAUTION The use of ring gaskets or excessive bolt torque may damage valve flanges.

VALVE START-UP PROCEDURE

When the swing check valve with weight arm and oil cushion is completely installed, follow the steps outlined below to place valve into service. A combination of the weight and oil cushion adjustments may be necessary depending on the valve's optional equipment configuration and the installed system performance.

Become familiar with the following adjustments that will affect the closing characteristics of the swing check valve's disc.

LEVER AND WEIGHT ADJUSTMENTS

Moving the weight in towards the hinge pin centerline will increase the disc's closing time and moving the weight out away from the pivot shaft center-line will decrease the disc's closing time. Note that the position of the weights can also affect how far the valve's disc opens under low or moderate flow conditions.

BOTTOM-MOUNTED OIL CUSHION ADJUSTMENTS

Using a bicycle tire pump inject air into the air fitting until the pressure is 50 psi higher than the water system pressure on the discharge side of the check valve. The air pressure acts to counterbalance the force created by the internal water pressure acting on the area of the snubber rod. The air pressure and cushion spring work to extend the snubber rod when the check valve opens.

There is a flow control valve externally mounted on the oil cushion cylinder. Start with the flow control

valve fully open (counterclockwise). To increase the cushioning effect (increase closure time) the flow control valve should be partially closed clockwise. Do not fully close the flow control valve or the main check valve will be prevented from closing fully. The unit is designed to control the closing time between 2 and 5 seconds.

CAUTION

Flow control valves should not be used at settings below the blue band (second from the bottom). Lower settings will allow small particles of silt present in the hydraulic fluid to clog the valve and cause the oil cushion to bind and result in damage to the valve or cushion.

SIDE-MOUNTED OIL CUSHION FLOW CONTROL VALVE ADJUSTMENTS

There is a flow control valve externally mounted on the oil cushion cylinder(s). Start with the flow control valve fully open (counterclockwise). To increase the cushioning effect (increase closure time) the flow control valve should be partially closed clockwise. Do not fully close the flow control valve or the main check valve will be prevented from closing fully and cause reverse flow through the valve and the pump. The flow control valve controls 90% of the closing stroke. The last 10% of the stroke can be slowed by adjusting the internal oil cushion in the cylinder head.

INITIAL SETTINGS

1. Before starting pump and placing valve into service, care must be taken to insure that the pump's intake structure is free of foreign objects such as lumber, tools, rocks, etc., which can damage the swing check valve.
2. When equipped with an oil cushion, the flow control valve will be set in the fully open position.
3. Connect the weight as far as possible from the center-line of the hinge pin and bolt to hold the weight secure.

CAUTION

These initial settings provide the fastest check valve closure.

STAYFLOW'S SWING CHECK VALVE OPERATION, MAINTENANCE AND INSTALLATION

The closure time should be selected, tested, set, and determined by the user or his designee who is expert in the installed piping system as the system's response to the valve's closure can vary greatly and the system induced transient pressure can cause severe damage to the valve and other piping system components.

TROUBLESHOOTING

Several problems and solutions are presented below to assist you in troubleshooting the valve assembly in an efficient manner.

- Leakage at Hinge Pin: Adjust or replace packing.
- Leakage at Cover or Flanges: Tighten cover or flange bolts, replace cover seal or flange gasket.
- Valve Leaks When Closed: Inspect disc seat for damage or debris. Clean or replace as needed. Inspect body stainless steel seating surface for damage or debris. Clean, polish, or replace as needed.
- Valve Does Not Open: Check for obstruction in valve or pipeline; see disassembly procedure. Operating pressure may be less than cracking pressure. If less than 0.5 psig, review application with factory.

DISASSEMBLY

The valve can be disassembled without removing it from the pipeline. The valve may also be removed from the pipeline. All work on the valve should be performed by a skilled mechanic with proper tools and a power hoist for larger valves. Disassembly may be required to inspect the disc for wear or the valve for debris or deposits.

Refer to Figure 4 for parts identification. Always relieve pressure and drain pipeline before working on the valve.

WARNING

The pipeline must be relieved of all pressure and drained before removing the valve or the valve cover or pressure may be released causing bodily harm.

WEIGHT AND LEVER REMOVAL

1. Support or prepare to lift weight (31). Carefully remove nut (35), washer (36), and bolt (34).
2. Remove weight (31). Note: Mark or record the weight (31) location on the lever arm (30).
3. Remove bolt (33) and lever (30).
4. Remove Key (32).
5. Remove weight and lever and cylinder bracket (40), bolts (46) and washers (47).

OIL CUSHION REMOVAL

1. Support or prepare to lift cylinder (42). Carefully remove clevis pins (43 and 44).
2. Remove cylinder (42).
3. Remove bolt (46) and lever (45).
4. Remove Key (32).
5. Remove weight and lever and cylinder bracket (40), bolts (46) and washers (47).

VALVE DISASSEMBLY

1. Remove the cover bolts, nuts, and washers (24, 28, & 29) on the top cover.
2. Pry cover (2) loose and lift off valve body. Valves 14" and larger have 3 tapped holes in cover for lifting eyes. See Table 2 for lifting eye bolt sizes.
3. If desired, remove stop bolt (60), washer (61) and nut (62). The stop bolt (60) should be match marked to assure re-installation to the same extension length.
4. Sling and support yoke arm (4) and disc (3) slightly off the seat (23)
5. Remove bolts (20), washers (19) and o-ring (22) from blind hinge cover (18-2).
6. Remove bolts (20) and washers (19) from through hinge cover (18-1).
7. Remove packing (16) and packing shim (15).
8. Push hinge pin from keyed end out of blind end side until retaining ring (21) can be removed. Remove retaining ring (21).
9. Continue to push hinge pin out until blind end bushing (14) moves out and can be removed. Remove bushing (14).
10. Push hinge pin back into the blind end until the bushing (14) on the keyed and of the hinge pin is moved enough to remove. Remove bushing (14).
11. Slide the supported yoke arm (4) and disc (3) back and forth on the hinge pin until the key (6) can be removed from between the yoke arm (4) and the body (1). Note: Take care not to damage the disc seat (8) or the body seat (11)

STAYFLOW'S SWING CHECK VALVE OPERATION, MAINTENANCE AND INSTALLATION

while moving yoke arm (4) and disc (3).

Remove key (6)

12. Remove hinge pin (5) from keyed end.
13. Lift the supported yoke arm (4) and disc (3) and place on a clean floor or pallet.
14. If desired, disassemble yoke arm (4), retaining rings (25), disc pins (24), and disc (3).
15. Remove seat retaining bolts (10), washer (9), seat retaining segments (7) and rubber seat (8).
16. Remove body seat (11). In 12" and smaller valves, the seat (11) is screwed into the body and must be threaded into place. In 14" and large the seat (11) is held into the body with set screws (12). Remove the body seat (11), set screws (12), and o-ring (23).
17. Clean and inspect parts. Replace worn parts as necessary and lubricate parts with FDA grease.

STAYFLOW'S SWING CHECK VALVE OPERATION, MAINTENANCE AND INSTALLATION

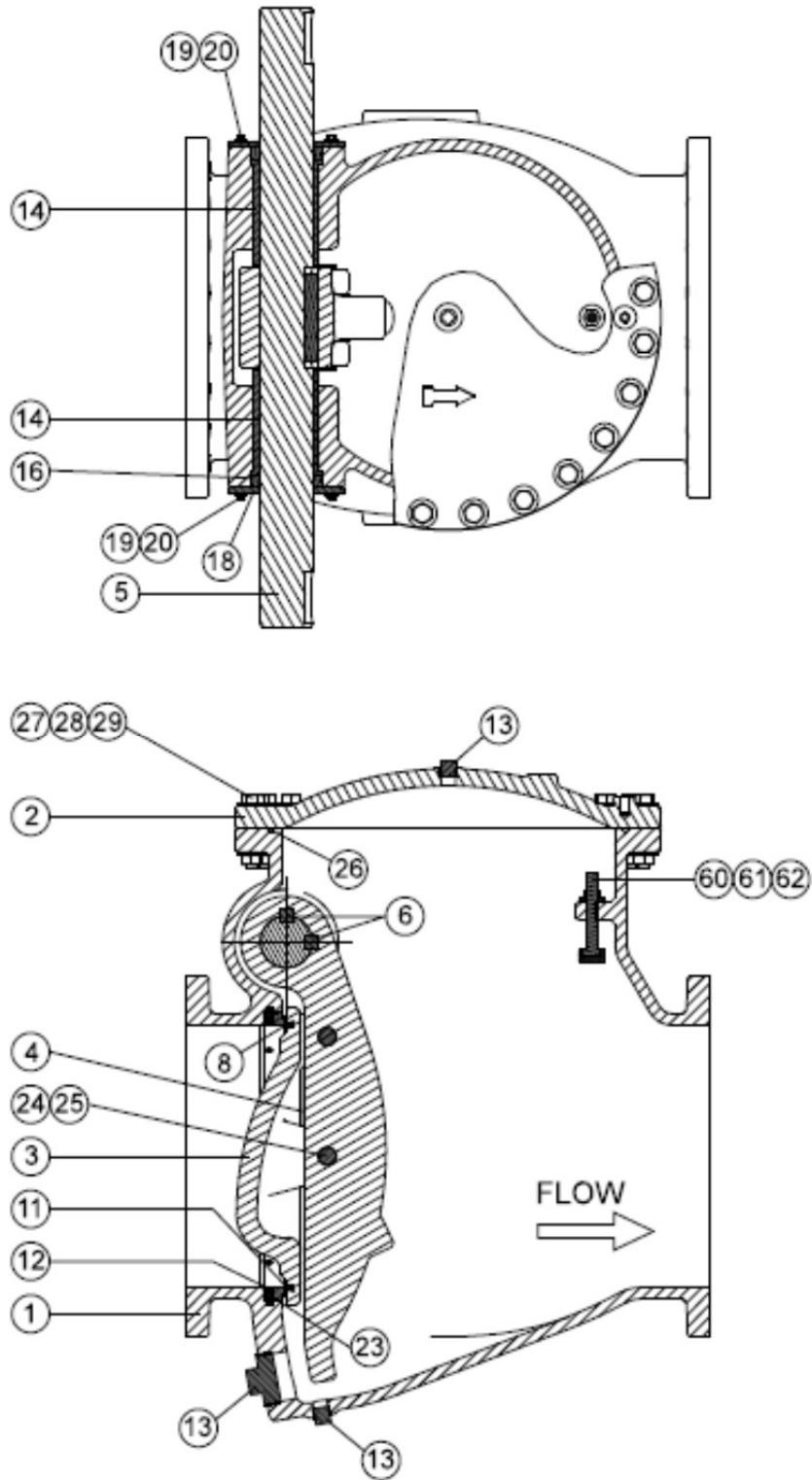
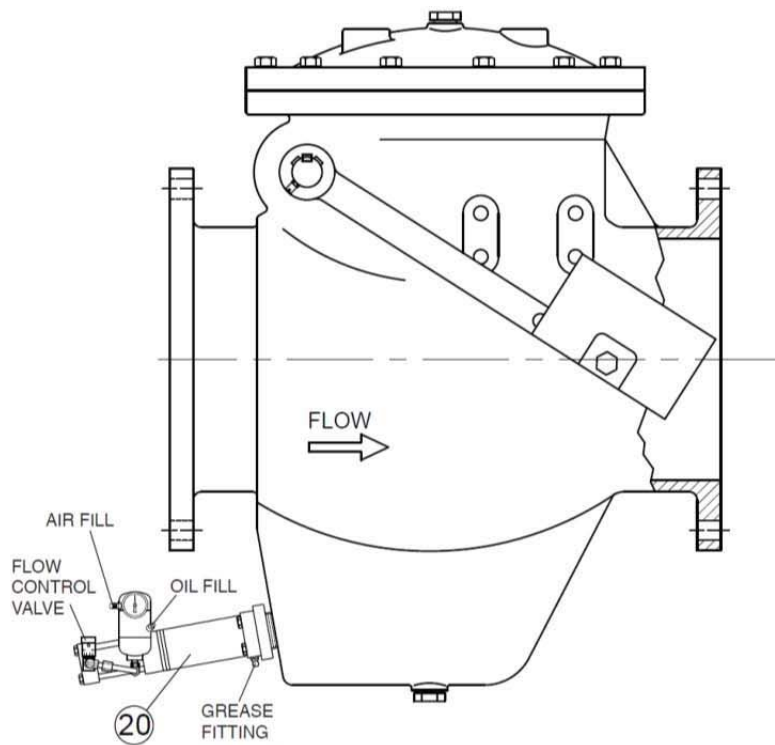
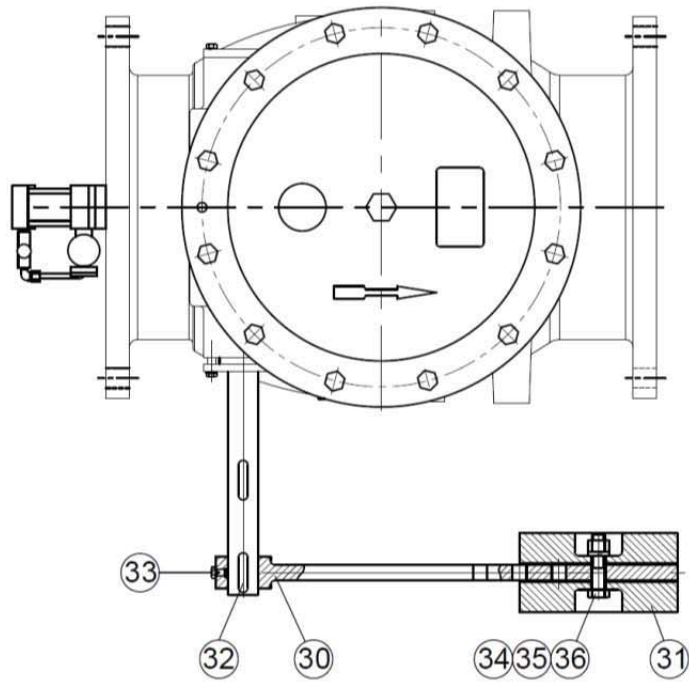

FIGURE 4. SWING CHECK VALVE PARTS CONSTRUCTION

STAYFLOW'S SWING CHECK VALVE OPERATION, MAINTENANCE AND INSTALLATION



STAYFLOW'S SWING CHECK VALVE OPERATION, MAINTENANCE AND INSTALLATION

FIGURE 5. BOTTOM-MOUNTED OIL CUSHION PARTS CONSTRUCTION

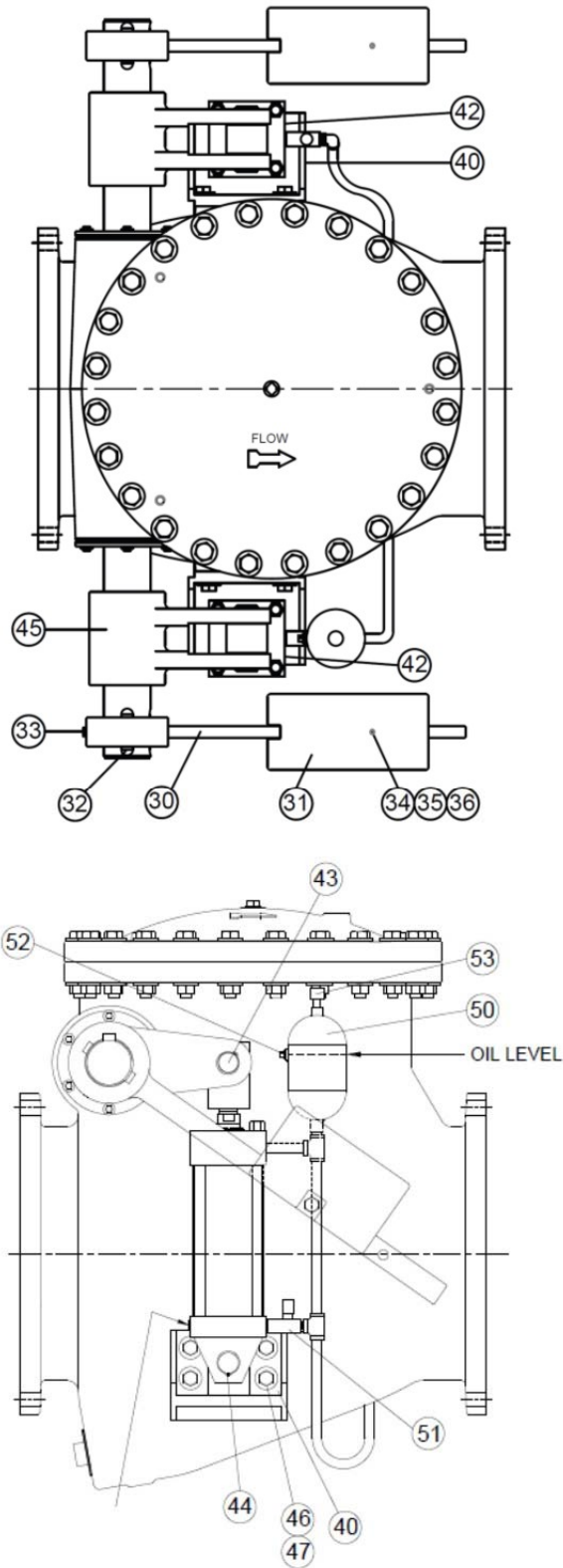

STAYFLOW'S SWING CHECK VALVE OPERATION, MAINTENANCE AND INSTALLATION

FIGURE 6. SIDE-MOUNTED OIL CUSHION PARTS CONSTRUCTION

TABLE 3. PARTS AND MATERIALS OF CONSTRUCTION			
PART NO.	*	PART NAME	MATERIAL
1		Body	Ductile Iron (2" To 24"), Cast Iron (30" To 48")
2		Cover	Ductile Iron (2" To 24"), Cast Iron (30" To 48")
3		Disc	Ductile Iron
4		Arm	Ductile Iron
5		Hinge Pin	Stainless Steel
6		Hinge Key	Stainless Steel
7	*	Seat Retaining Segment	Ductile Iron
8	*	Disc Seat	Buna-N or Bronze
9		Flat Washer	Stainless Steel
10	*	Hex Hd. Cap Screw	Stainless Steel
11		Seat	Stainless Steel
12		Set Screw	Stainless Steel
13		Pipe Plug	Steel
14	*	Bushing	Aluminum Bronze
15	*	V-Packing Shim	Nylon
16	*	V-Packing	Buna-N
17		Packing (Pop) Shim	Stainless Steel
18-1		Hinge Cover - Thru	Ductile Iron
18-2		Hinge Cover - Blind	Ductile Iron
19		Flat Washer	Plated Steel
20		Hinge Cover Bolt (Fig 4)	Plated Steel
20		Bot. Oil Cushion (Fig 5)	Aluminum Bronze
21		Retaining Ring	Stainless Steel
22	*	O-Ring	Buna-N
23		O-Ring	Buna-N
24		Disc Pin	Stainless Steel
25		External Retaining Ring	Stainless Steel
26	*	O-Ring	Buna-N
27		Flat Washer	Plated Steel
28		Hex Hd. Bolt	Plated Steel
29		Hex Nut	Plated Steel
30		Weight Lever	Ductile Iron
31		Weight	Ductile Iron
32		Key	Steel
33		Bolt	Plated Steel
34		Bolt	Plated Steel
35		Nut	Plated Steel
36		Washer	Plated Steel
40		Cylinder Bracket	Steel
42		Cylinder	Steel
43		Cylinder Pin	Plated Steel
44		Clevis Pin	Plated Steel
45		Cylinder Lever	Ductile Iron

STAYFLOW'S SWING CHECK VALVE OPERATION, MAINTENANCE AND INSTALLATION

46		Bolt	Plated Steel
47		Washer	Plated Steel
50	*	Stop Bolt	Stainless Steel with Buna N
51	*	Flat Washer	Stainless Steel
52	*	Hex Nut	Stainless Steel
60		Cushion Tank	Stainless Steel
61		Tank Vent	Stainless Steel
62		Fill Port	Stainless Steel
63		Flow Control Valve	Brass

* = Recommended Spare Part

RE-ASSEMBLY

All work on the valve should be performed by a skilled mechanic with proper tools and a power hoist for larger valves.

VALVE RE-ASSEMBLY

- Lubricate body seat o-ring (23) and body seat (11) with an FDA grease. Install body seat oring (23) and body seat (11). In 12" and smaller valves, the seat (11) is screwed into the body. In 14" and large the seat (11) is held into the body with set screws (12). Remove the body seat (11), set screws (12), and o-ring (23)
- Install rubber seat (8), seat retaining segments (7), washers (9), and seat retaining bolts (10) onto disc. Torque bolts to values listed in Table 4 below. Note: Take caution to protect the rubber seat from damage during the remainder of the assemble process.

Valve Size	Bolt Size	Torque (ft-lbs)
2" to 4"	M5	5
6" to 20"	M8	10
24" to 48"	M10	20

- Assemble yoke arm (4), retaining rings (25), disc pins (24), and disc (3).
- Sling and support yoke arm (4) and disc (3).
- Lift and hang the supported yoke arm (4) and disc (3) and place into body (1) with yoke hinge boss nestled in the hinge pin recess area.
- Install hinge pin (5) and yoke key (6) from keyed end engaging the key into the keyway of the yoke (4). Note: The hinge pin may be installed with the key oriented toward either side of the valve. The keyed end of hinge pin (5) must be oriented to the side where the

spring assembly, lever & weight assembly, and /or air cushion assembly is to be mounted.

- Install bushings (14) from both ends of hinge pin (5).
- Push hinge out the non-keyed end of the hinge pin until the retaining ring (21) can be installed and install the retaining ring.
- Push hinge (5) back into the body until retaining ring (21) is seating at the back of the bushing (14). Install bolts, (20) washers (19) and o-ring (22) with blind hinge cover (18-2).
- Install packing (16) and packing shim (15).
- Install bolts (20) and washers (19) with through hinge cover (18-1).
- Install stop bolt (60), washer (61) and nut (62). Set at desired extension length.
- Lubricate cove o-ring (26) and grove on top of body (1) with an FDA grease. Install o-ring (26) on top of body (1). Place cover (2) on top of body in the correct orientation with the flow arrow pointing away from the hinge pin.
- Install cover bolts (28), washers (27), and nuts (29). Torque bolts and nuts to the values listed in Table 5 below in several graduated steps using the cross-over bolt tightening method.

Valve Size	Bolt Size	Torque (ft-lbs)
2" to 2½"	M10	50
3"-4"	M12	75
6"-18"	M20	250
20"-36"	M24	500
42"-48"	M30	750

- Install pipe plugs (13) are not installed into body (1) and Cover (2) if not already installed. Note: Vent, drain and/or air release valves may

STAYFLOW'S SWING CHECK VALVE OPERATION, MAINTENANCE AND INSTALLATION

also be installed into these ports in lieu of the pipe plugs furnished.

16. If desire, pressure test the body for packing and cover leaks. Adjust or replace as necessary.
17. Install spring assembly, lever and weight assembly and/or air cushion assembly.

WEIGHT AND LEVER RE-ASSEMBLY

1. Install weight and lever and cylinder bracket (40), bolts (46) and washers (47).
2. Install key (32).
3. Install lever (30). Note: Lever has multiple keyways for installing at various orientations.
4. Install weight (31) at the desired location.
5. Install nut (35), washer (36), and bolt (34) on lever (30).

OIL CUSHION RE-ASSEMBLY

1. Install weight and lever and cylinder bracket (40), bolts (46) and washers (47).
2. Install Key (32).
3. Install bolt (46) and lever (45).
4. Install cylinder (42) with clevis pins (43 and 44).

PARTS AND SERVICE

Parts and service are available from your local representative or the factory. Make note of the valve Model No. and Working Pressure located on the valve nameplate and contact:

Stayflow Valve and Mfg. Corp.
2323 W. Hubbard Street,
Chicago IL, 60126
Phone: (312) 428-4750
www.stayflowproducts.com

A sales representative will quote prices for parts or arrange for service as needed.

STAYFLOW'S SWING CHECK VALVE

OPERATION, MAINTENANCE AND INSTALLATION

LIMITED WARRANTY

All products are warranted to be free of defects in material and workmanship for a period of one year from the date of shipment, subject to the limitations below.

If the purchaser believes a product is defective, the purchaser shall: (a) Notify the manufacturer, state the alleged defect and request permission to return the product; (b) if permission is given, return the product with transportation prepaid. If the product is accepted for return and found to be defective, the manufacturer will, at his discretion, either repair or replace the product, f.o.b. factory, within 60 days of receipt, or refund the purchase price. Other than to repair, replace or refund as described above, purchaser agrees that manufacturer shall not be liable for any loss, costs, expenses or damages of any kind arising out of the product, its use, installation or replacement, labeling, instructions, information or technical data of any kind, description of product use, sample or model, warnings or lack of any of the foregoing. NO OTHER WARRANTIES, WRITTEN OR ORAL, EXPRESS OR IMPLIED, INCLUDING THE WARRANTIES OF FITNESS FOR A PARTICULAR PURPOSE AND MERCHANTABILITY, ARE MADE OR AUTHORIZED. NO AFFIRMATION OF FACT, PROMISE, DESCRIPTION OF PRODUCT OF USE OR SAMPLE OR MODEL SHALL CREATE ANY WARRANTY FROM MANUFACTURER, UNLESS SIGNED BY THE PRESIDENT OF THE MANUFACTURER. These products are not manufactured, sold or intended for personal, family or household purposes.



Stayflow VALVE AND MANUFACTURING CORP.

2323 W. Hubbard Street • Chicago IL 60612
Phone: 312-428-4750 • Stayflowproducts.com