

Meets **LEAD-FREE⁽¹⁾** requirements!

MODEL YAF
 (ALUMINUM BRONZE)

New design includes **gauge taps** as standard on YAF models



FEATURES

SIZE RANGE : 2" ~ 12"

❖ **ASTM B148 BODY MATERIAL**

ALUMINUM BRONZE IS STRONGER AND LESS LIKELY TO CORRODE THAN OTHER BRONZE ALLOYS, MAKING THEM A PREFERRED CHOICE FOR SEA WATER AND OTHER APPLICATIONS WHERE CORROSION IS A CONCERN. BECAUSE OF ITS COPPER CONTENT, MARINE ORGANISMS CANNOT COLONIZE ON THE MATERIAL. ADDITIONALLY, STAYFLOW'S YAF IS USED FOR POTABLE WATER APPLICATIONS AS IT MEETS LEAD FREE STATUTES REQUIRING THAT THE LEAD CONTENT IN THE WETTED SURFACES IS 0.25% OR LESS AS DETERMINED BY A WEIGHTED AVERAGE.

❖ **NEW DESIGN WITH GAUGE TAPS**

STAYFLOW'S YAF HAS CONVENIENT GAUGE TAPS FURNISHED WITH A PLUG ON BOTH THE INLET AND OUTLET SIDES OF SIZES 2" THROUGH 12". THESE TAPS ALLOW FOR EASY INSTALLATION OF PRESSURE GAUGES TO MONITOR DIFFERENTIAL PRESSURE AND DETERMINE WHEN SCREEN CLEANING IS NECESSARY.

❖ **LARGE STRAINING CAPACITY**

WITH ITS LARGE BODY AND SIZABLE STRAINING ELEMENT, THE YS54 PROVIDES EXCELLENT OPEN AREA RATIOS THAT ARE TYPICALLY TWO-AND-A-HALF TIMES LARGER THAN THE CORRESPONDING PIPELINE, MINIMIZING PRESSURE DROP ACROSS THE VALVE.

❖ **PRECISION MACHINED SEATS**

PRECISION MACHINED SCREEN SEATS IN BOTH THE BODY AND COVER HELP TO ENSURE ACCURATE POSITIONING OF THE SCREEN DURING REASSEMBLY AFTER CLEANING. ALSO, THE MACHINED BODY SEATS ENABLE FINER FILTRATION BY PREVENTING DEBRIS BYPASS.

❖ **SELF-CLEANING CAPABILITY**

WITH A TAPPED NPT BLOW-OFF CONNECTION, THIS UNIT CAN BE FITTED WITH A BLOW-DOWN VALVE WHICH FACILITATES CLEANING OF THE STRAINING ELEMENT. PLEASE CONTACT FACTORY FOR MORE INFORMATION.

TECHNICAL

PRESSURE/TEMPERATURE RATING (2)
 AB - ASTM B148 GR. 9D - CLASS 150

WOG (Non-shock): 225 PSI @ 150 °F

1. The YAF meets requirements for lead free use in potable water systems. The lead content in the wetted surfaces is 0.25% or less as determined by a weighted average. For more information on lead free requirements, contact Titan Flow Control, Inc.
2. The above listed temperatures are theoretical and may vary during actual operating conditions.

APPLICATIONS

GENERAL APPLICATION: Y-STRAINERS ARE INSTALLED IN A PIPING SYSTEM TO REMOVE UNWANTED DEBRIS FROM THE PIPELINE, PROTECTING EXPENSIVE EQUIPMENT DOWNSTREAM SUCH AS PUMPS, METERS, SPRAY NOZZLES, COMPRESSORS, AND TURBINES. THEY CAN BE PLACED IN A HORIZONTAL OR VERTICAL PIPELINE AS LONG AS THE SCREEN IS IN A DOWNWARD POSITION. STRAINING IS ACCOMPLISHED VIA AN INTERNAL PERFORATED OR MESH LINED STRAINING ELEMENT, THE SIZE OF WHICH SHOULD BE DETERMINED BASED ON THE SIZE OF THE SMALLEST PARTICLE TO BE REMOVED.

SERVICING: THE STRAINING ELEMENT NEEDS REGULAR CLEANING TO PREVENT DEBRIS BUILD UP. IT IS NOT ADVISABLE TO ALLOW THE DIFFERENTIAL PRESSURE TO INCREASE BY 20 PSI. ALTHOUGH CLEANING NORMALLY REQUIRES THE REMOVAL OF THE STRAINING ELEMENT, INSTALLING AND USING A STAYFLOW BLOW-OFF DRAIN VALVE CAN INCREASE THE TIME BETWEEN CLEANINGS.

The above data represents common market and service applications. No representation or guarantee, expressed or implied, is given due to the numerous variations of concentrations, temperatures and flow conditions that may occur during actual service.

BILL OF MATERIALS ⁽¹⁾

No.	PART	YAF
1	Body	Aluminum Bronze ASTM B148 Gr. 9D
2	Cover	Aluminum Bronze ASTM B148 Gr. 9D
3	Straining Element ⁽²⁾	Stainless Steel
4	Gasket ⁽²⁾	Teflon
5	Cap Screw	Stainless Steel or Silicon Bronze
6	NPT Plug (Blow-off)	Aluminum Bronze ASTM B148 Gr. 9D
7	NPT Plug (Gauge Taps)	Stainless Steel ⁽³⁾

1. Bill of Materials represents standard materials. Equivalent or better materials may be substituted at the manufacturer's discretion.
2. Denotes recommended spare parts.
3. NPT Plug also available in other materials.

Body Material Application Notes:

- Aluminum Bronze (ASTM B148) is a preferred material for lead-free wye strainers, meeting requirements for potable water systems by containing 0.25% lead or less by average weight on all wetted parts.
- Aluminum Bronze is strong and corrosion resistant, meeting the needs of many various applications, such as seawater and marine.

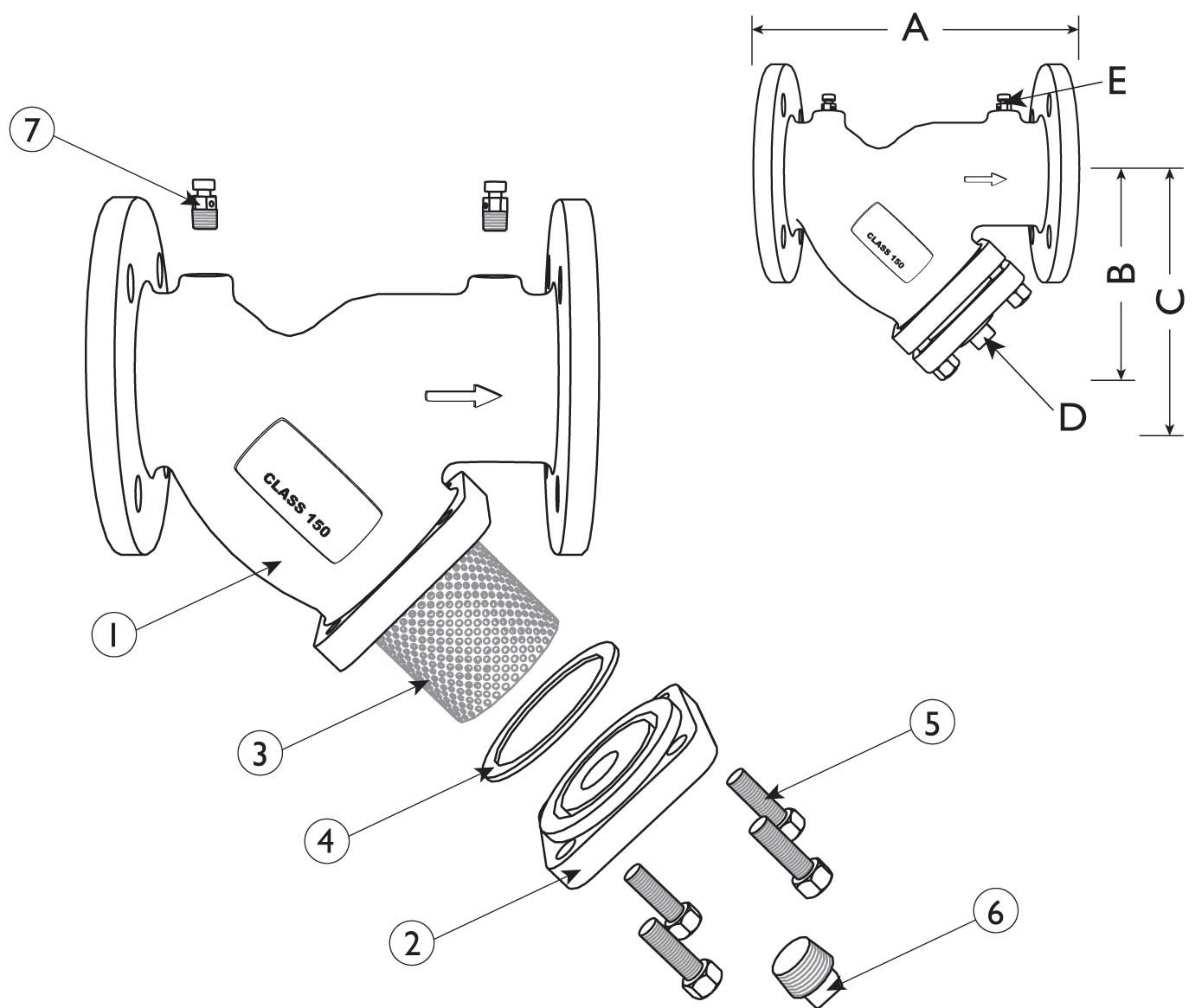

DIMENSIONS AND PERFORMANCE DATA ⁽¹⁾

SIZE	in	2	2 1/2	3	4	5	6	8	10	12
	mm	50	65	80	100	125	150	200	250	300
A DIMENSION FACE TO FACE ⁽²⁾	in	7.75	9.75	10.06	12.12	C/F	18.30	21.37	26.00	C/F
	mm	197	248	256	308	C/F	465	543	660	C/F
B DIMENSION CENTER LINE TO BOTTOM	in	5.25	6.50	7.00	8.25	C/F	13.50	15.50	18.50	C/F
	mm	133	165	178	210	C/F	343	394	470	C/F
C DIMENSION SCREEN REMOVAL	in	7.00	9.75	10.00	12.00	C/F	20.00	22.75	28.00	C/F
	mm	178	248	254	305	C/F	508	578	712	C/F
D NPT Plug BLOW-OFF	in	1/2	1	1	1 1/2	C/F	2	2	2	C/F
	mm	15	25	25	40	C/F	50	50	50	C/F
E NPT Plug GAUGE TAPS	in	1/4	1/4	1/4	1/4	C/F	1/4	1/4	1/4	C/F
	mm	8	8	8	8	C/F	8	8	8	C/F
APPROXIMATE ASSEMBLED WEIGHT	lb	22.0	34.0	38.0	64.0	C/F	132.0	240.0	C/F	C/F
	kg	10.0	15.4	17.2	29.0	C/F	59.9	108.9	C/F	C/F
Flow Coefficient	C _v	70	110	160	260	C/F	570	950	1600	C/F

1. Dimensions and weights are for reference only. When required, request certified drawings.
2. Face to face dimension includes raised face. These values have a tolerance of ±0.06 in (±2.0 mm) for sizes 10" and lower and a tolerance of ±0.12 in (±3.0 mm) for sizes 12" and larger.

PRESSURE - TEMPERATURE RATINGS

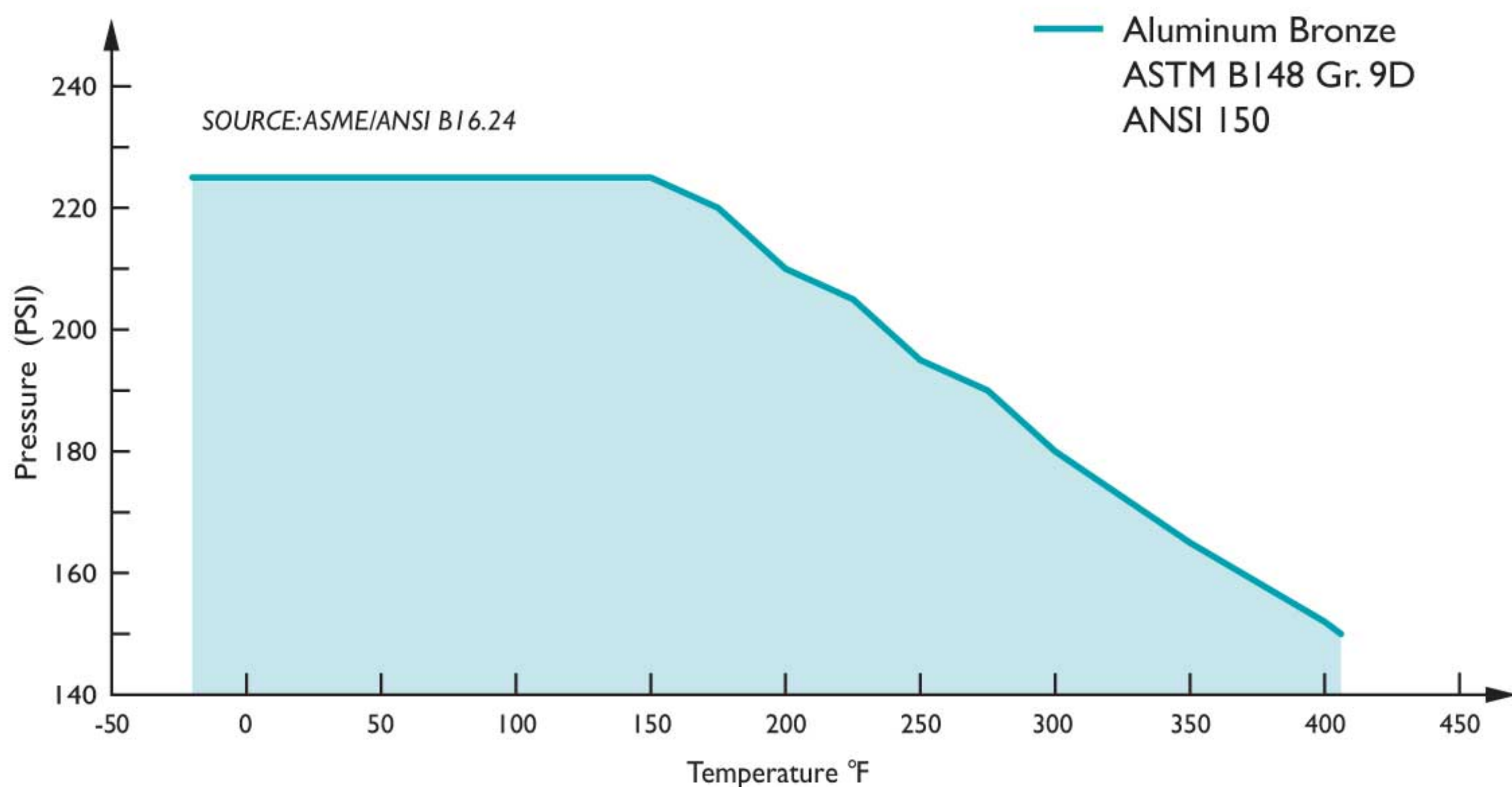

PRESSURE - TEMPERATURE RATING

ANSI Class 150

ASTM B148 Gr. 9D

WOG (Non-shock):

225 PSI @ 150 °F

STANDARD SCREEN SELECTIONS

Size	Liquid	Open Area	Steam	Open Area
2" ~ 4"	1/16 (.0625)	41%	1/32 (.033)	28%
5" ~ 8"	1/8 (.125)	40%	3/64 (.045)	36%
10" ~ 12"	1/8 (.125)	40%	30 Mesh Lined	44.8%

REFERENCED STANDARDS & CODES

CODE	DESCRIPTION
ASME/ANSI B16.24	Cast Copper Alloy Pipe Flanges and Flanged Fittings