

MODEL YDG
 (DUCTILE IRON)



FEATURES

SIZE RANGE : 2" ~ 12"

- ♦ **UL LISTED**
STAYFLOWS YDG GROOVED END DESIGN CAN BE QUICKLY AND EASILY INSTALLED.
- ♦ **LARGE STRAINING CAPACITY**
WITH ITS LARGE BODY AND SIZABLE STRAINING ELEMENT, THE YDG PROVIDES EXCELLENT OPEN AREA RATIOS THAT MEET THE REQUIREMENT OF UL SUBSET 321.
- ♦ **RUGGED CONSTRUCTION**
DURABLE HEAVY WALL CONSTRUCTION OF DUCTILE IRON PROVIDES HIGH STRENGTH AND LONG SERVICE LIFE.
- ♦ **SELF-CLEANING CAPABILITY**
WITH A TAPPED NPT BLOW-OFF CONNECTION, THIS UNIT CAN BE FITTED WITH A BLOW-DOWN VALVE WHICH FACILITATES CLEANING OF THE STRAINING ELEMENT. PLEASE CONTACT FACTORY FOR MORE INFORMATION.
- ♦ **EPOXY PAINTED**
ALL UNITS ARE EPOXY PAINTED TO HELP RESIST RUST AND CORROSION. STAYFLOW ALSO OFFERS EPOXY COATING AS AN OPTION FOR THE YDG.
- ♦ **POTABLE WATER/FDA APPROVED COATINGS AVAILABLE**



IN ADDITION TO ITS LEAD FREE, DUCTILE IRON BODY, TITAN CAN PROVIDE NSF/ASME AND FDA APPROVED EPOXY COATINGS WHICH MAKE THIS PRODUCT SUITABLE FOR POTABLE WATER AND FOOD CONTACT APPLICATIONS. NUMEROUS OPTIONS ARE AVAILABLE. PLEASE CONTACT US FOR MORE DETAILS.

TECHNICAL

PRESSURE/TEMPERATURE RATING
SIZES 2" ~ 12"

WOG (Non-shock): 300 PSI @ 160 °F

APPLICATIONS

GENERAL APPLICATION: Y-STRAINERS ARE INSTALLED IN A PIPING SYSTEM TO REMOVE UNWANTED DEBRIS FROM THE PIPELINE, PROTECTING EXPENSIVE EQUIPMENT DOWNSTREAM SUCH AS PUMPS, METERS, SPRAY NOZZLES, COMPRESSORS, AND TURBINES. THEY CAN BE PLACED IN A HORIZONTAL OR VERTICAL PIPELINE AS LONG AS THE SCREEN IS IN A DOWNWARD POSITION. STRAINING IS ACCOMPLISHED VIA AN INTERNAL PERFORATED OR MESH LINED STRAINING ELEMENT, THE SIZE OF WHICH SHOULD BE DETERMINED BASED ON THE SIZE OF THE SMALLEST PARTICLE TO BE REMOVED.

SERVICING: THE STRAINING ELEMENT NEEDS REGULAR CLEANING TO PREVENT DEBRIS BUILD UP. IT IS NOT ADVISABLE TO ALLOW THE DIFFERENTIAL PRESSURE TO INCREASE BY 20 PSI. ALTHOUGH CLEANING NORMALLY REQUIRES THE REMOVAL OF THE STRAINING ELEMENT, INSTALLING AND USING A TITAN BLOW-OFF DRAIN VALVE CAN INCREASE THE TIME BETWEEN CLEANINGS.

The above data represents common market and service applications. No representation or guarantee, expressed or implied, is given due to the numerous variations of concentrations, temperatures and flow conditions that may occur during actual service.

BILL OF MATERIALS ⁽¹⁾

No.	PART	YDG
1	Body	Ductile Iron ASTMA395
2	Cover	Ductile Iron ASTMA395
3	Straining Element ⁽²⁾	Stainless Steel
4	Gasket ⁽²⁾	EPDM
5	Studs	Carbon Steel A193-B7
6	Nuts	Carbon Steel A194-2H
7	NPT Plug (Blow-off)	Carbon Steel A105
8	NPT Plugs (Gauge Taps)	Carbon Steel A105

1. Bill of Materials represents standard materials. Equivalent or better materials may be substituted at the manufacturer's discretion.
2. Denotes recommended spare parts.

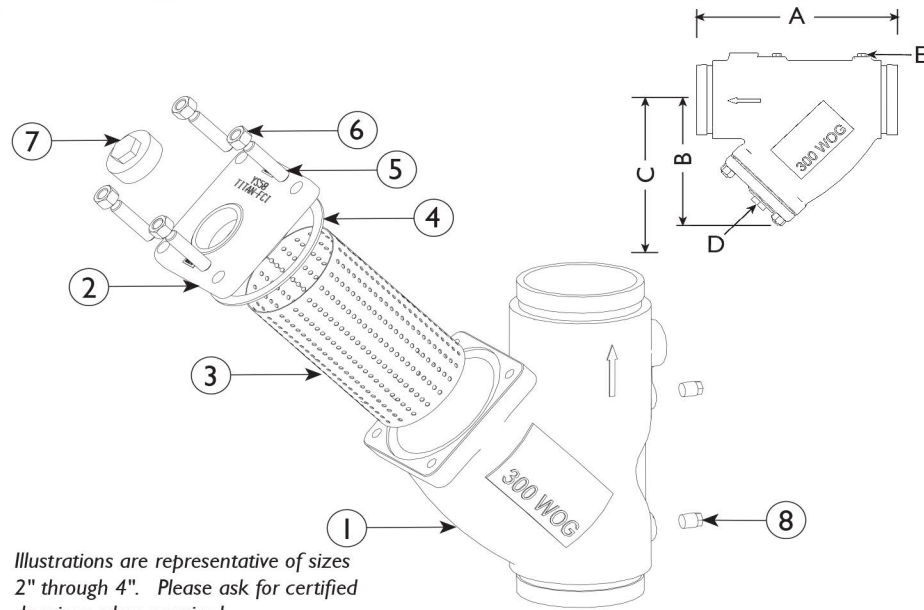

Illustrations are representative of sizes 2" through 4". Please ask for certified drawings when required.

DIMENSIONS AND PERFORMANCE DATA ⁽¹⁾

SIZE	in	2	2 1/2	3	4	5	6	8	10	12
	mm	50	65	80	100	125	150	200	250	300
O.D. DIMENSION	in	2.38	2.88	3.50	4.50	5.56	6.63	8.63	10.75	12.75
	mm	60.3	73.0	88.9	114.3	141.3	168.4	219.1	273.1	323.9
A DIMENSION FACE TO FACE (FLAT FACE)	in	7.88	10.00	10.13	12.13	15.62	18.5	21.63	25.75	29.87
	mm	200	254	256	308	397	470	550	655	759
B DIMENSION CENTER LINE TO BOTTOM	in	5.25	6.50	7.0	8.25	11.25	13.5	15.5	18.5	21.38
	mm	133	165	178	210	286	343	394	470	543
C DIMENSION SCREEN REMOVAL	in	7.0	9.75	10.0	12.0	20.0	20.0	22.75	28.0	30
	mm	178	248	254	305	508	508	578	711	762
D NPT Plug BLOW-OFF	in	1/2	1	1	1 1/2	2	2	2	2	2
	mm	15	25	25	40	50	50	50	50	50
E NPT Plugs GAUGETAPS	in	1/4	1/4	1/4	1/4	1/4	1/4	1/4	1/4	1/4
	mm	8	8	8	8	8	8	8	8	8
APPROXIMATE ASSEMBLED WEIGHT	lb	10.5	15.6	19.8	38.0	59.2	84.1	186.3	215	447
	kg	4.8	7.1	9.00	17.5	26.9	38.2	84.5	98	203
Flow Coefficient	C _v	70	110	160	260	400	570	950	1600	2200

SCREEN AREAS

Size	Area In ²	Size	Area In ²
2"	28.8	6"	238
2-1/2"	45.5	8"	345
3"	54.7	10"	537
4"	91.1	12"	596
5"	144		

1. Dimensions and weights are for reference only. When required, request certified drawings.

2. Face to face values have a tolerance of ±0.06 in (±2.0 mm) for sizes 10" and lower and a tolerance of ±0.12 in (±3.0 mm) for sizes 12" and larger.

PRESSURE - TEMPERATURE RATINGS ⁽¹⁾

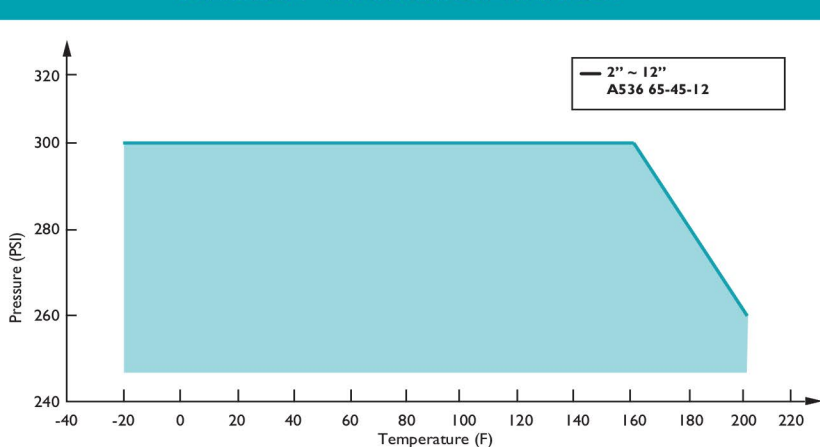

1. This chart displays the pressure-temperature ratings for the YDG

PRESSURE - TEMPERATURE RATING

A395 2" ~ 12"

WOG (Non-shock): 300 PSI @ 160 °F

SCREEN SELECTIONS

Size	Perf	Open Area
2" ~ 4"	1/16 (.0625)	41%
5" ~ 12"	1/8 (.125)	40%

REFERENCED STANDARDS & CODES

STANDARD	DESCRIPTION
UL Subject 321	Pipeline Strainers
ULC / ORD-C 321	Pipeline Strainers (Canada)
AWWA C606	Grooved and Shouldered Joints