

## MODEL YET

(ECO - BRASS)

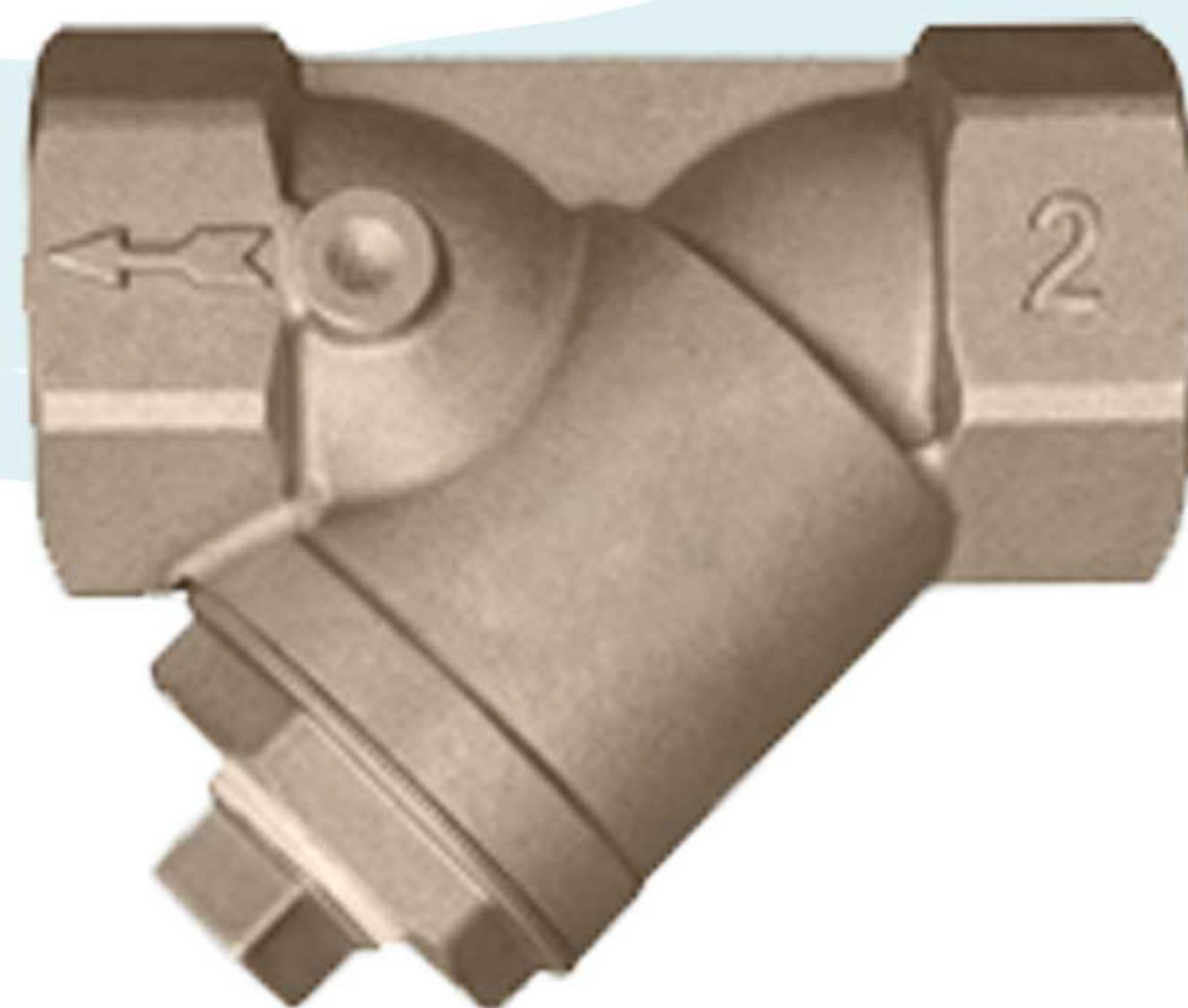

## FEATURES

SIZE RANGE : 1/4" ~ 3"

❖ **NEW ECO-BRASS® MATERIAL**

ECO-BRASS® IS A LEAD-FREE, ENVIRONMENTALLY FRIENDLY BRASS MATERIAL. TITAN HAS UPGRADED OUR YET AND YES MODELS TO MEET THE DEMANDS OF THE MARKETPLACE THAT REQUIRE A LEAD-FREE BRASS ALTERNATIVE. ECO-BRASS® IS A HIGH-PERFORMANCE LEAD-FREE BRASS THAT PROVIDES EXCELLENT STRENGTH AND CORROSION RESISTANCE. ECO-BRASS® IS NSF COMPLIANT.

❖ **LARGE STRAINING CAPACITY**

WITH ITS LARGE BODY AND SIZABLE STRAINING ELEMENT, THE YET AND YES PROVIDE EXCELLENT OPEN AREA RATIOS THAT ARE TYPICALLY TWO-AND-A-HALF TIMES LARGER THAN THE CORRESPONDING PIPELINE, MINIMIZING PRESSURE DROP ACROSS THE VALVE.

❖ **PRECISION MACHINED SEATS**

PRECISION MACHINED SCREEN SEATS IN BOTH THE BODY AND CAP HELP TO ENSURE ACCURATE POSITIONING OF THE SCREEN DURING REASSEMBLY AFTER CLEANING. ALSO, THE MACHINED BODY SEATS ENABLE FINER FILTRATION BY PREVENTING DEBRIS BYPASS.

❖ **SELF-CLEANING CAPABILITY**

WITH A TAPPED NPT BLOW-OFF CONNECTION, THIS UNIT CAN BE FITTED WITH A BLOW-DOWN VALVE WHICH FACILITATES CLEANING OF THE STRAINING ELEMENT. PLEASE CONTACT FACTORY FOR MORE INFORMATION.

❖ **THREADED CAP**

STAYFLOW'S YET AND YES HAVE STRAIGHT THREADS TO PERMIT EASY CAP REMOVAL FOR CLEANING AND PROPER ALIGNMENT WHEN REASSEMBLING STRAINER.

❖ **POTABLE WATER/FDA APPLICATIONS**



THIS PRODUCT IS SUITABLE FOR POTABLE WATER AND FOOD CONTACT APPLICATIONS. NUMEROUS OPTIONS ARE AVAILABLE. PLEASE CONTACT US FOR MORE INFORMATION REGARDING NSF APPLICATIONS.

## TECHNICAL

PRESSURE/TEMPERATURE RATING <sup>(1)</sup>

**YET (THREADED)**

WOG (Non-shock): 200 PSI @ 150 °F

1. The above listed temperatures are theoretical and may vary during actual operating conditions.

## APPLICATIONS

**GENERAL APPLICATION:** Y-STRAINERS ARE INSTALLED IN A PIPING SYSTEM TO REMOVE UNWANTED DEBRIS FROM THE PIPELINE, PROTECTING EXPENSIVE EQUIPMENT DOWNSTREAM SUCH AS PUMPS, METERS, SPRAY NOZZLES, COMPRESSORS, AND TURBINES. THEY CAN BE PLACED IN A HORIZONTAL OR VERTICAL PIPELINE AS LONG AS THE SCREEN IS IN A DOWNWARD POSITION. STRAINING IS ACCOMPLISHED VIA AN INTERNAL PERFORATED OR MESH LINED STRAINING ELEMENT, THE SIZE OF WHICH SHOULD BE DETERMINED BASED ON THE SIZE OF THE SMALLEST PARTICLE TO BE REMOVED.

**SERVICING:** THE STRAINING ELEMENT NEEDS REGULAR CLEANING TO PREVENT DEBRIS BUILD UP. IT IS NOT ADVISABLE TO ALLOW THE DIFFERENTIAL PRESSURE TO INCREASE BY 20 PSI. ALTHOUGH CLEANING NORMALLY REQUIRES THE REMOVAL OF THE STRAINING ELEMENT, INSTALLING AND USING A STAYFLOW BLOW-OFF DRAIN VALVE CAN INCREASE THE TIME BETWEEN CLEANINGS.

*The above data represents common market and service applications. No representation or guarantee, expressed or implied, is given due to the numerous variations of concentrations, temperatures and flow conditions that may occur during actual service.*







312-428-4750 www.stayflowproducts.com

# "Y" (WYE) STRAINER MODEL YET

ANSI Class  
125

Threaded Ends • ANSI Class 125 • Silicone Brass

## BILL OF MATERIALS <sup>(1)</sup>

No.	PART	YET
1	Body	Silicone Brass (C87850) ASTM A584
2	Cap	Silicone Brass (C87850) ASTM A584
3	Straining Element <sup>(2)</sup>	Stainless Steel
4	Gasket <sup>(2)</sup>	Teflon 1/4" - 2"    Buna-N 2 1/2" - 3"
5	NPT Plug (Blow-off)	Silicone Brass (C87850) ASTM A584

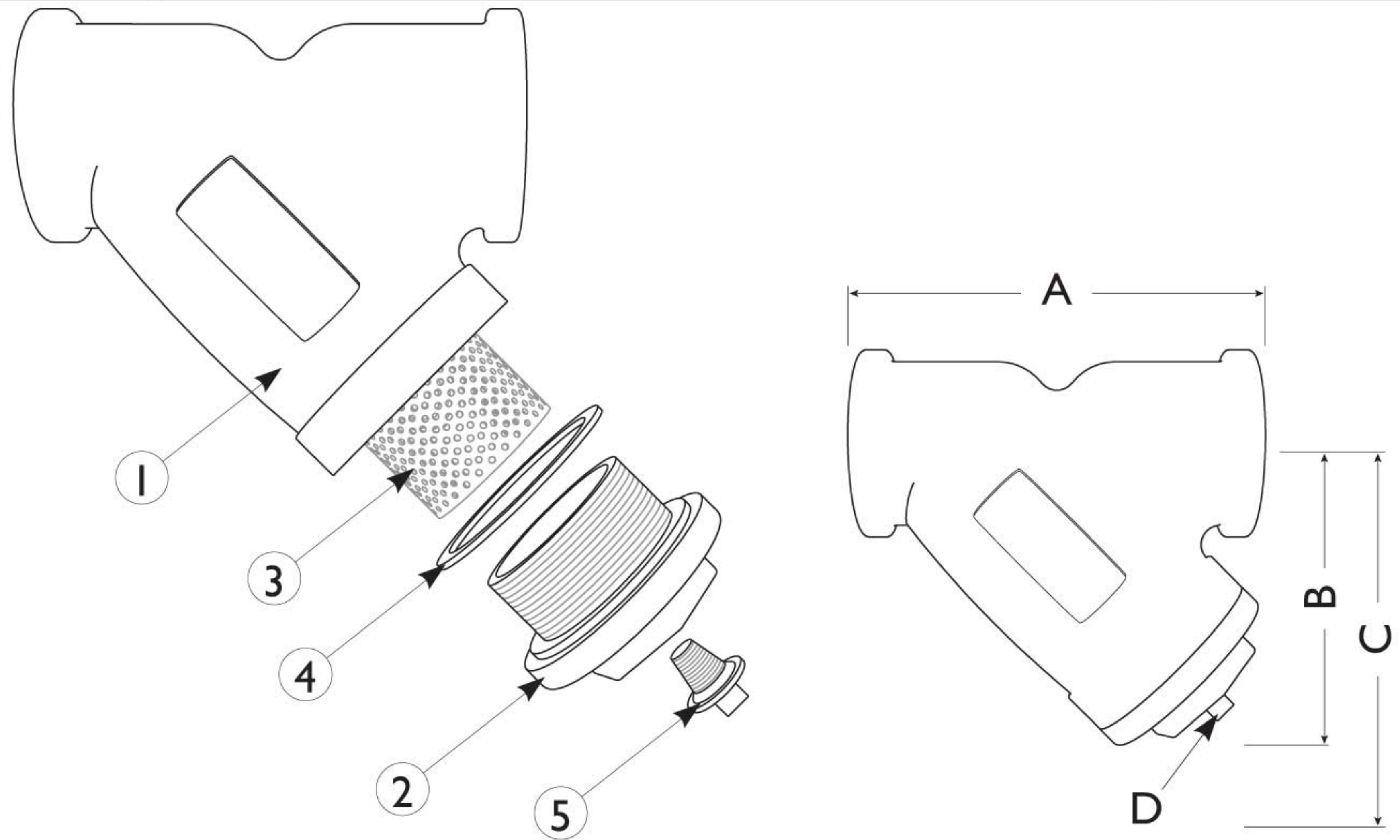

1. Bill of Materials represents standard materials. Equivalent or better materials may be substituted at the manufacturer's discretion.
2. Denotes recommended spare parts.

## DIMENSIONS AND PERFORMANCE DATA <sup>(1)</sup>

SIZE	in	1/4	3/8	1/2	3/4	1	1 1/4	1 1/2	2	2 1/2	3	
	mm	8	10	15	20	25	32	40	50	65	80	
<b>A DIMENSION</b> FACE TO FACE (YS 55) <sup>(2)</sup>	in	C/F	2.38	2.80	3.18	3.70	4.41	4.93	5.91	C/F	10.60	
	mm	C/F	61	71	81	94	112	125	150	C/F	269	
<b>A DIMENSION</b> FACE TO FACE (YS 56) <sup>(2)</sup>	in	C/F	C/F	2.75	3.36	3.80	4.58	5.33	6.11	C/F	11.40	
	mm	C/F	C/F	70	86	97	116	136	155	C/F	290	
<b>B DIMENSION</b> CENTER LINE TO BOTTOM (YS 55)	in	C/F	1.39	1.60	1.86	2.13	2.50	2.92	3.60	C/F	5.50	
	mm	C/F	36	41	48	54	64	74	92	C/F	140	
<b>B DIMENSION</b> CENTER LINE TO BOTTOM (YS 56)	in	C/F	C/F	1.60	1.86	2.13	2.50	2.92	3.60	C/F	7.0	
	mm	C/F	C/F	41	48	54	64	74	92	C/F	140	
<b>C DIMENSION</b> SCREEN REMOVAL	in	C/F	3.75	4.0	4.25	4.75	6.0	7.0	8.0	C/F	10.0	
	mm	C/F	95	102	108	121	152	178	203	C/F	254	
<b>D NPT Plug</b> BLOW-OFF	in	C/F	1/4"	1/4"	1/4"	1/2"	1/2"	3/4"	1"	C/F	C/F	
	mm	C/F	8	8	8	15	15	20	25	C/F	C/F	
<b>ASSEMBLED WEIGHT</b> YS 55-THREADED (APPROXIMATE)	lb	C/F	0.35	0.45	0.85	1.30	2.00	2.65	4.30	C/F	12.90	
	kg	C/F	0.16	0.21	0.39	0.6	0.91	1.21	1.95	C/F	5.85	
<b>Flow Coefficient</b>	C <sub>v</sub>		0.7	2	8	15	22	38	42	70	110	160

1. Dimensions and weights are for reference only. When required, request certified drawings.
2. Face to face values have a tolerance of ±0.06 in (±2.0 mm).

## PRESSURE - TEMPERATURE RATING - YS 55-EB (Threaded)

(1/4" - 3")

WOG (Non-shock): 200 PSI @ 150 °F

## STANDARD SCREEN SELECTIONS

Size	Liquid	Open Area	Steam	Open Area
1/4" ~ 2"	20 mesh	51.8%	30 mesh	44.8%
2 1/2" ~ 3"	1/16 (.0625)	41%	3/64 (.045)	36%

## REFERENCED STANDARDS & CODES

CODE	DESCRIPTION
ASME/ANSI B16.15	Cast Bronze Threaded Fittings
ASTM A584	Copper Alloy Sand Castings

## PRESSURE - TEMPERATURE RATINGS <sup>(1)</sup>

