

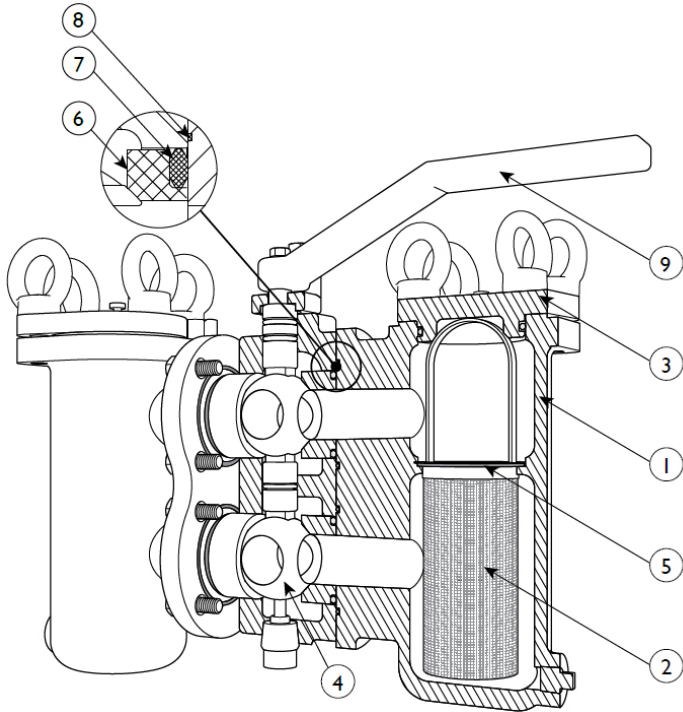

# DCF300 Flanged & DCT300 Threaded Carbon Steel Duplex Strainers



## 300# Class



PRESSURE RATING (psig) ANSI CLASS 300				
W.O.G.	TEMP RANGE	STEAM	SEAL - MAX (F)	BODY - MAX (F)
720 @ 100 F	-20 to 250F	N R	250 F	450 F

FORGED STEEL THREADS - PER ASME/ANSI B16.11  
PIPE FLANGES - PER ASME/ANSI B16.5

BILL OF MATERIALS		
ITEM	DESCRIPTION	MATERIAL
1	Housing	Carbon Steel - ASTM A216 Gr. WCB
2	Straining Element	Stainless Steel
3	Cover	Carbon Steel - ASTM A216 Gr. WCB
4	Ball	Stainless
5	O-ring	Buna-N
6	Seat Seal	PTFE
7	Seals	Buna-N
8	O-ring Body	Buna-N

DEFAULT SCREEN - 1/16" PERFORATIONS, 41% OPEN AREA

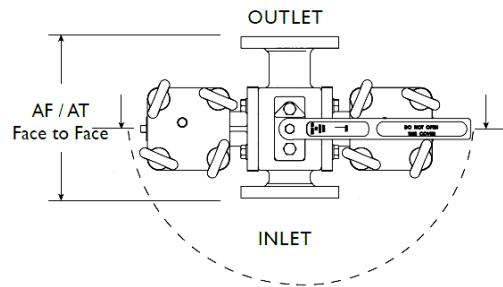
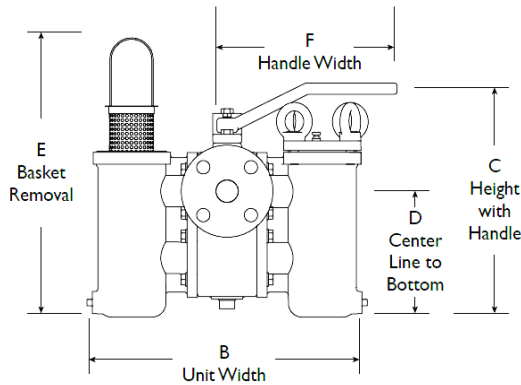

DIMENSIONS (in) / PERFORMANCE							
SIZE	AF	AT*	B	C	D	E	Cv
3/4	NA	5.59	12.95	11.0	5.83	15.4	13
1	7.4	5.59	12.95	11.0	5.83	15.4	14
1-1/4	9.84	7.5	15.12	14.2	8.3	21.3	19
1-1/2	9.84	7.5	15.12	14.2	8.3	21.3	24
2	11.18	10.0	18.43	17.7	10.7	26.4	42
2-1/2	14.28	11.5	22.05	22.0	13.7	35.0	68
3	14.28	11.5	22.0	22.0	13.7	35.0	105
4	16.61	NA	26.85	25.2	15.9	41.0	180

\* AT=THREADED DIMENSION (Threaded version available from 3/4"-3" sizes)