

STAYFLOW

DSFT Flanged & DSTT Threaded Stainless Steel Duplex Strainers

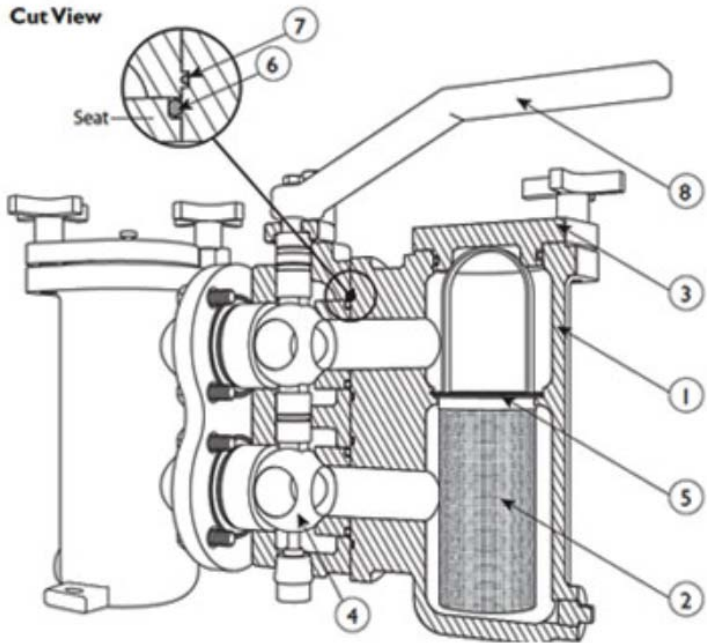

PRESSURE RATING (psig) ANSI CLASS 150				
W.O.G.	MAX LIQ.	STEAM	SEAL - MAX (F)	BODY - MAX (F)
200 @ 150 F	200 @ 150 F	N R	250 F	450 F

FORGED STEEL THREADS - PER ASME/ANSI B16.11
PIPE FLANGES - PER ASME/ANSI B16.5

BILL OF MATERIALS		
ITEM	DESCRIPTION	MATERIAL
1	Housing	Stainless Steel - ASTM A351 Gr. CF8M
2	Straining Element	Stainless
3	Cover	Stainless Steel - ASTM A351 Gr. CF8M
4	Ball	Stainless
5	O-ring Straining Element	Viton
6	Seat Seal	PTFE
7	Seals	Viton
8	Handle	Carbon Steel - Zinc Coated

DEFAULT SCREEN - 1/16" PERFORATIONS, 41% OPEN AREA

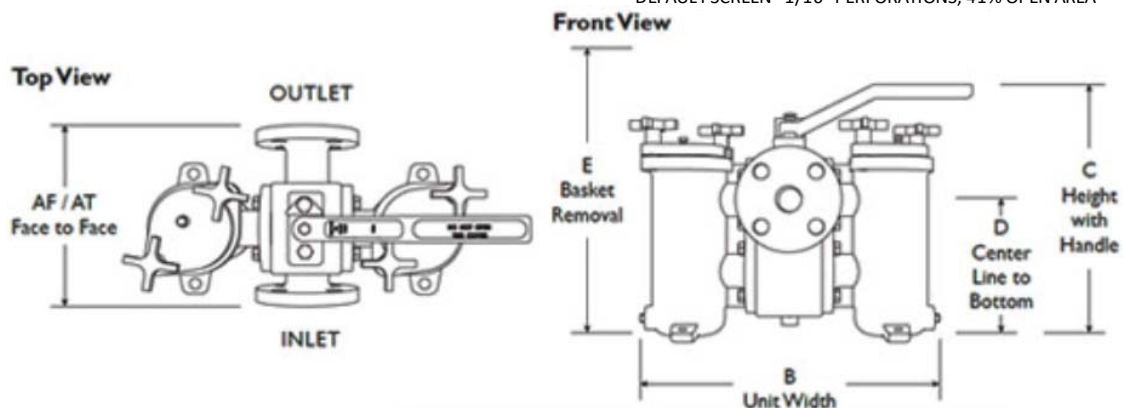

DIMENSIONS (in) / PERFORMANCE								
SIZE	A _F	A _T	B	C	D	E	Cv	Wt. (lb)
3/4	NA	5-9/16	12-15/16	11	5-13/16	15-3/8	13	44
1	7	5-9/16	12-15/16	11	5-13/16	15-3/8	14	47
1-1/4	9-3/8	7-1/2	15-1/8	14-1/4	8-5/16	21-5/16	19	74
1-1/2	9-3/8	7-1/2	15-1/8	14-1/4	8-5/16	21-5/16	24	74
2	10-5/8	10	18-3/8	17-3/4	10-3/4	26-3/8	42	122
2-1/2	13-1/2	11-1/2	22	22	13-3/4	35	68	237
3	13-1/2	NA	22	22	13-3/4	35	105	238
4	16	NA	26-7/8	25-1/4	15-7/8	41	180	374

* AT=THREADED