

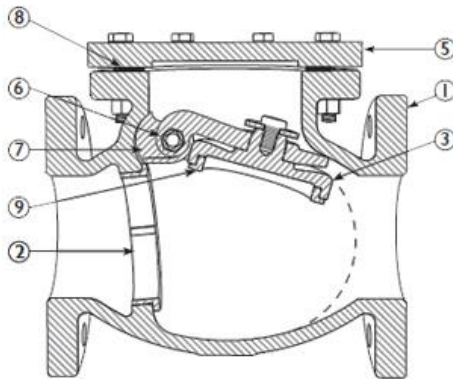

VCSF-IG1IBT Full Body Check Valve

Swing Style, Class 125, Cast Iron Body, Cast Iron Disc, Bronze Seat

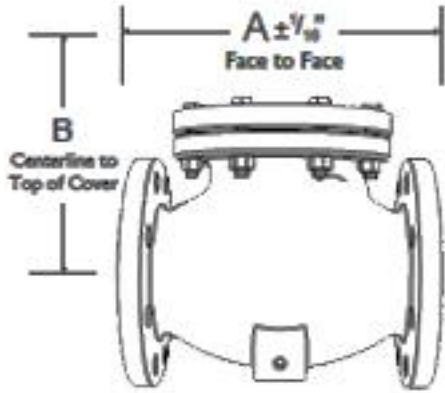

BILL OF MATERIALS		
NO.	PART	MATERIAL
1	Body	Cast Iron ASTM A126 Gr.B
2	Seat	Bronze ASTM B62 C83600
3	Disc	Cast Iron ASTM A126 Gr.B
4	Side Plug	Brass ASTM B16 C3600
5	Cover	Cast Iron ASTM A126 Gr.B
6	Hanger Pin	Stainless Steel AISI 420
7	Hanger	Ductile Iron ASTM A536 65-45-12
8	Gasket	Non-asbestos
9	Disc Seat	Buna-N

DIMENSIONS & PERFORMANCE DATA									
SIZE	2	2.5	3	4	5	6	8	10	12
A (in)	8.00	8.50	9.50	11.50	13.00	14.00	19.50	24.50	27.52
B (in)	5.00	5.40	5.79	6.54	7.50	8.55	10.45	11.81	13.47
WT (lbs)	25.35	36.38	46.30	55.12	92.60	110.0	230.0	370.38	537.93
Cv	48	76	109	198	310	446	801	1260	1821

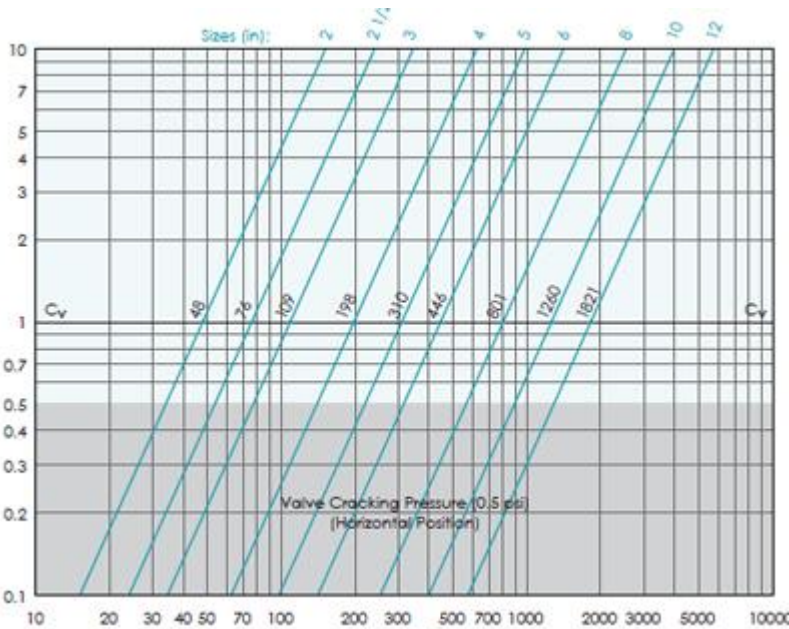

PRESS/TEMP RATINGS	
WOG	200PSI @ 125F

