

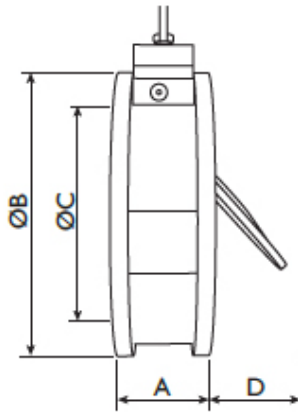

VCSS-DW1SBT Swing Check Valve

Class 150# Ductile Iron Body, Stainless Steel Disc, Viton Seat

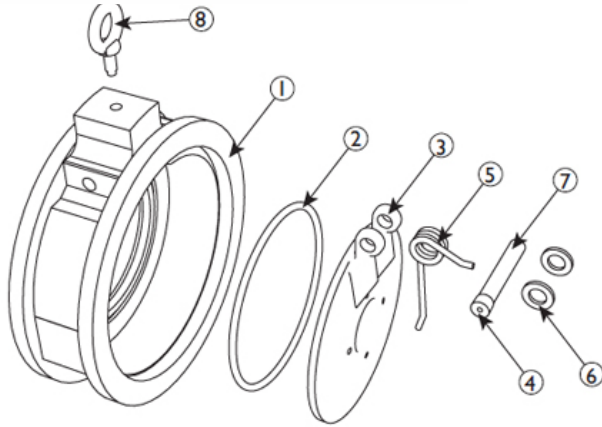

BILL OF MATERIALS		
NO.	PART	MATERIAL
1	Body	Ductile Iron ASTM A536
2	Seat	Buna-N O-Ring
3	Disc	Stainless Steel AISI 316
4	Plug	Carbon Steel ASTM A307B
5	Spring	Series 300 Stainless Steel
6	Spacer	PTFE Commercial
7	Shaft	Stainless Steel AISI 316
8	Eye Bolt	Carbon Steel ASTM A307B

DIMENSIONS & PERFORMANCE DATA									
SIZE	2	2.5	3	4	5	6	8	10	12
A (in)	2.12	2.38	2.62	2.62	3.25	3.75	5.0	5.5	7.12
B (in)	4.00	4.88	5.25	6.88	7.75	8.75	11.00	13.38	16.13
C (in)	1.31	1.85	2.06	3.00	3.75	4.75	6.44	7.63	9.50
D(in)	0.75	1.00	0.80	1.87	3.30	2.70	3.00	4.62	4.00
WT (lbs)	4.0	5.0	7.0	11.0	16.0	16.0	32.0	44.0	60.0
Cv	62	109	166	318	471	720	1384	2298	4153

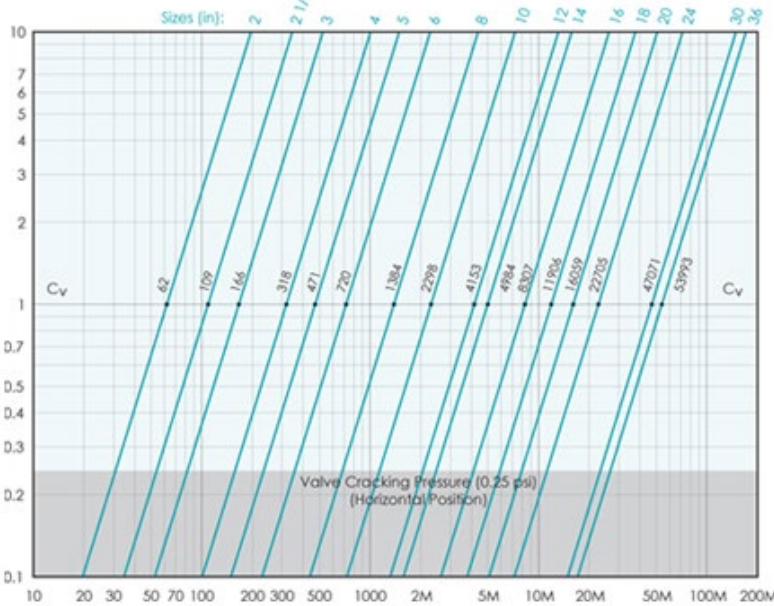

PRESS/TEMP RATINGS	
WOG	250PSI @ 100F
Viton	-20 to 250F MAX

