

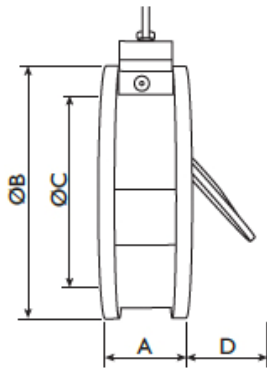

VCSS-SW1SPT Swing Check Valve

Class 150# SS Body, Stainless Steel Disc, PTFE Seat

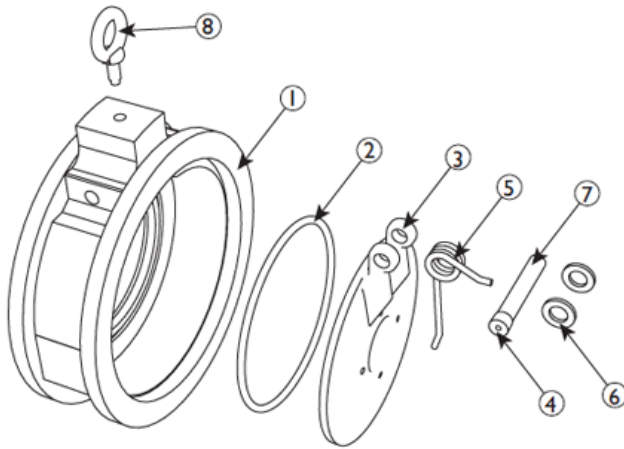

BILL OF MATERIALS		
NO.	PART	MATERIAL
1	Body	Stainless Steel A351 Gr. CF8M
2	Seat	PTFE Commercial O-Ring
3	Disc	Stainless Steel AISI 316
4	Plug	Stainless Steel AISI 316
5	Spring	Series 300 Stainless Steel
6	Spacer	PTFE Commercial
7	Shaft	Stainless Steel AISI 316
8	Eye Bolt	Carbon Steel ASTM A307B

DIMENSIONS & PERFORMANCE DATA									
SIZE	2	2.5	3	4	5	6	8	10	12
A (in)	2.38	2.62	2.62	2.62	3.25	3.75	5	5.75	7.12
B (in)	4.00	4.875	5.25	6.75	7.75	8.625	10.875	13.25	16.0
C (in)	1.313	1.85	2.063	3.00	3.75	4.75	6.438	7.625	9.50
D(in)	0.5	0.62	0.8	1.87	3.3	2.7	3	4.35	4
WT (lbs)	5.0	6.0	8.0	12.0	18.0	22.0	30.0	48.0	140.0
Cv	62	109	166	318	471	720	1384	2298	4153

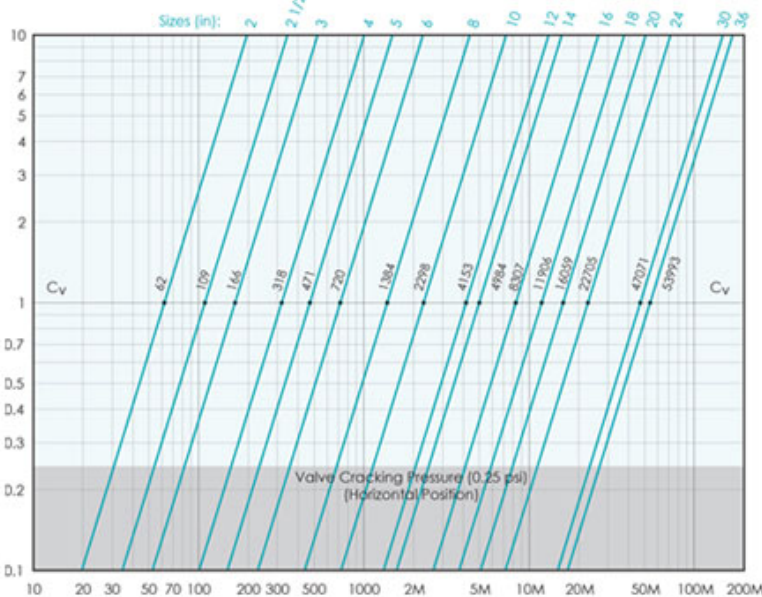

PRESS/TEMP RATINGS	
WOG	285PSI @ 100F
PTFE	17 to 248F MAX

