

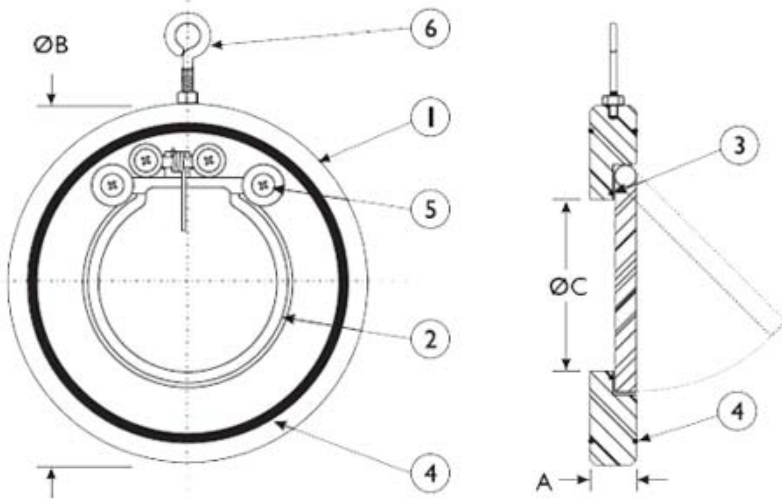

# VCSP-SW1SPT Wafer Style Check Valve

Swing Style, Class 150, SS Body, SS Disc, PTFE Seat



BILL OF MATERIALS		
NO.	PART	MATERIAL
1	Body	Stainless Steel A240 Gr. 316
2	Disc	Stainless Steel A351 Gr. CF8M
3	Seat	PTFE
4	Body Seal	PTFE
5	Bolt	Stainless Steel Type 304-SS
6	Eye Bolt	Chrome Plated

DIMENSIONS & PERFORMANCE DATA														
SIZE	2	2.5	3	4	5	6	8	10	12	14	16	18	20	24
A	0.75	0.75	0.75	0.75	0.75	0.75	1.125	1.125	1.5	1.75	2.0	2.375	2.5	2.5
B	4.13	4.90	5.25	6.90	7.75	8.75	11.00	13.375	16.125	17.75	20.25	21.5	24	28.25
C	1.25	1.625	2.125	3.0	3.375	4.375	6.125	8.0	9.5	10.625	12.25	14.125	16.125	19.25
WT	2.5	3.5	6.0	7.0	8.5	10.0	22.0	33.5	58.0	93.5	146.5	195.0	232.0	352.0
Cx	62	100	166	318	470	610	1250	2300	4150	4980	8225	11906	20000	27700

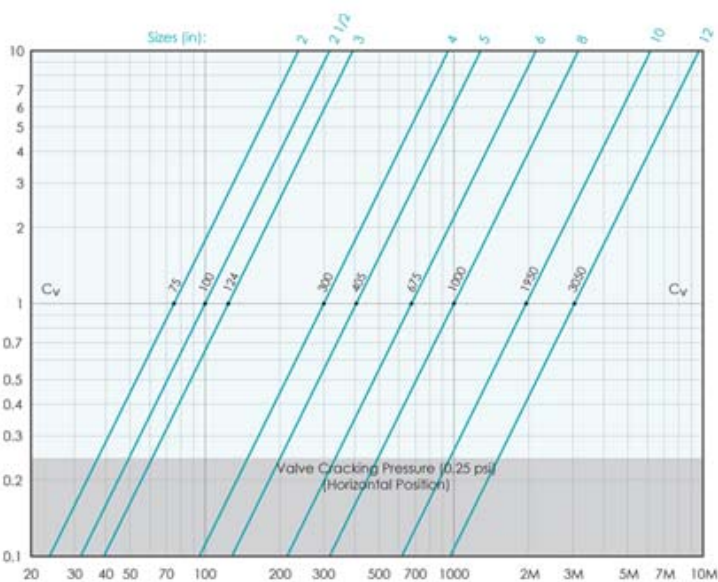

PRESS/TEMP RATINGS	
WOG	285PSI @ 100°F
PTFE	14 to 320°F MAX

