



# INSTALLATION, OPERATION, AND MAINTENANCE

## **PREFACE:**

This manual contains information concerning the installation, operation, and maintenance of Stayflow Control Check Valves. To ensure efficient and safe operation of Stayflow Model TDV Control Check Valves, the instructions in this manual should be thoroughly read and understood. This manual is general in nature and is not meant to take the place of an on-site, process engineer or pipe fitter. As such, Stayflow recommends that only experienced, skilled personnel be allowed to install and maintain Stayflow Model TDV Control Check Valves. Please retain this manual in a location where it is readily available for reference.

## **GENERAL INFORMATION:**

A Model TDV Control Check Valve is a heavy-duty, pump protection device that is installed on the discharge side of a pump. In this position, the Model TDV Valve provides all the functions normally required on the discharge side of a pump including: a spring loaded silent check valve, a balancing valve, and a shut-off valve. The disc of the Model TDV Valve is designed to automatically open (with as little as 1/2 psi line pressure) to allow system flow and shut (when line pressure reaches zero) to prevent flow reversal and water hammer.

Specific engineering design data, not contained in this manual, may be located within the Model TDV Control Check Valve Specification Sheet or on a certified Engineering drawing available by request.

Prior to selection of a Stayflow Model TDV Control Check Valve, the following factors must be determined:

- Material construction requirements of the Model TDV Valve.
- Design and working pressure/temperature requirements.
- Operating conditions (throttling, pressure drop, condensation, flow reversal, operation frequency, etc.).
- Service media type (liquid, gas, abrasive, corrosive, dirty, etc).
- Pipeline Media Flow-rate and Viscosity.
- Clean Start-up Pressure of the Pipeline.
- Space availability for installation.

Please contact Stayflow to assist in the determination of these requirements prior selection and purchase.



**Figure 1: Model TDV Control Check Valve**

## **UNPACKING AND INSPECTION:**

Upon receipt of product, it is important to follow these unpacking and inspection procedures.

All Stayflow Model TDV Control Check Valves are shipped in specialized shipping containers designed to prevent damage during transportation. If external damage to the shipping container is evident upon receipt of product, please request that a representative of the shipping carrier be present before unpacking the product.

- Carefully open the shipping container, following any instructions that may be marked on the container. Remove all packing material surrounding the Model TDV Valve and carefully lift it from the container. It is recommend to keep the shipping container and all packing material for reuse in storage or reshipment.

### **CAUTION:**

For large or heavy Model TDV Control Check Valves, the appropriate material handling equipment must be used to prevent injury and possible damage to the Model TDV Control Check Valve.

## **UNPACKING AND INSPECTION: Continued...**

- Visually inspect the Model TDV Valve for any signs of damage including scratches, loose parts, broken parts or any other physical damage that may have occurred during shipment. If damage is observed, immediately file a claim with the shipping carrier. Model TDV Valves that are damaged during transportation are the responsibility of the customer.  
For information regarding Stayflow's warranty policy, please refer to the last page of this document.
- Before installation, remove the flange protectors from the Tri-Flow Valve and inspected it internally for any loose or foreign materials that may have become trapped inside the Model TDV during transportation.
- If the Model TDV Valve is not required to be installed immediately, it should be stored indoors in a clean, dry, consistent temperature environment. It is also recommended to utilize the original shipping container and packing materials to properly store the Model TDV Valve. If long term storage is required, a desiccant may be necessary. This would be based upon the local, environmental storage conditions. Please consult a Stayflow Design Engineer to assist in this determination.
- When ready to install, remove any preservatives with solvent dampened cloths. Remove any loose material and protective packing material.

## **INSTALLATION:**

### Pre-Installation Checklist

- Ensure Working conditions (pressure and temperature) are within the specified capacity of the product being installed. Please refer to the certified Engineering drawings to assist in determining these values.
- Make sure that the construction material of the Strainer is chemically compatible with the media flowing in the pipeline.
- Inspect the Model TDV Control Check Valve's flange ends and the pipeline's mating flanges to ensure gasket surfaces are clean and free of defects. The pipeline should also be checked for proper alignment. Stayflow Model TDV Control CheckValves should never be utilized to realign an existing piping system.

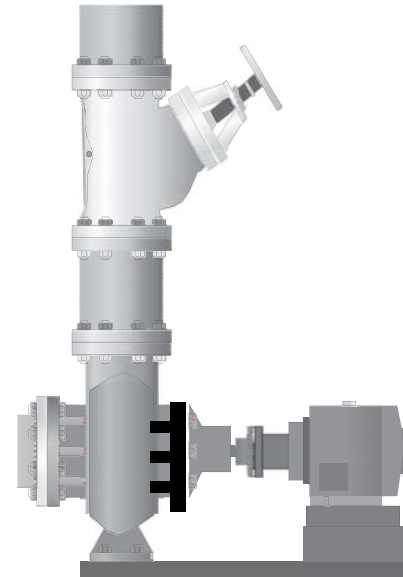

**Figure 2: Illustration of Installed Model TDV Valve with Pump**

### Pre-Installation Checklist continued...

- Ensure that the pipeline's mating flanges are the same type as the Model TDV Control Check Valve being installed. Raised face flange ends cannot be mated to flat face flange ends.
- Ensure the gap for product installation and Model TDV Valve's end to end length are within 1/4" gap for gasket installation. Also, check for sufficient clearance around the Model TDV Valve for maintenance operations.
- The appropriate handling equipment (joist and slings) should be available to lift larger units into position.

### Installation Procedure

#### Step 1:

The Stayflow Model TDV Valve may be installed in either the vertical or horizontal position on the discharge side (outlet) of the pump. In the vertical position the stem must be pointing up and in the horizontal position the stem must be pointing up and away from the pump.

Installation Procedure continued...

**Step 2:**

Place the Model TDV Valve into position, using the appropriate material handling equipment for large or heavy units. Ensure that the flow arrow (cast into the Model TDV Valve) is pointed away from the pump and the stem is pointing upward.

**CAUTION:**

Stayflow does not recommend mounting a Model TDV Valve directly to the pump.

**Step 3:**

Before proceeding, ensure that there is ample space around the Model TDV Valve to allow for maintenance operations.

**Step 4:**

For large Model TDV Valves, it is recommended to support the existing pipeline with pipe supports near the inlet and outlet connections before attempting installation.

**Step 5:**

Install a standard, ANSI (1/8" thick) flange gasket between the Model TDV Control Check Valve and pipeline flanges, on both sides. Install lubricated flange bolts and hand tighten. Flange bolts should then be tightened, using a star or crisscross pattern to evenly load the bolts, in accordance with established piping standards. This is illustrated in Figure 3.

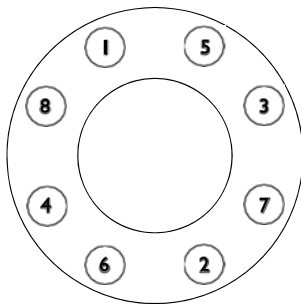

**Figure 3: Bolting Sequence Pattern**

**CAUTION:**

Excessive bolt torque may damage flanges. Please refer to established flange bolt torques for guidelines.



**OPERATION:**

Once proper installation has been successfully completed, start the system gradually, at start up as well as after shut down. This eliminates sudden shock to the strainer and other equipment in the line.

Start-up Procedure:

**CAUTION:**

Start system gradually, at start up as well as after shut down. This eliminates sudden shock to the TDV and other equipment in the line. This is **EXTREMELY** important for steam service.

**Step 1:**

Model TDV Valve's are shipped in the closed position, therefore slightly open the Model TDV Valve before starting the system. Once system is started, gradually adjust the disc opening (via the hand wheel) until the desired flow and pressure drop is reached. Stayflow recommends installing pressure gauges on either side of the Model TDV Valve to assist in determining the pressure differential.

**Step 2:**

Inspect flange connections for leaks. If leaking occurs, ensure that the flange bolts are properly tightened and check for piping misalignment

**Step 3:**

For future reference, make a note of the disc position as indicated by the graduated position indicator located on the rising stem.



# INSTALLATION, OPERATION, AND MAINTENANCE

## **MAINTENANCE:**

Stayflow Model TDV Control Check Valves are designed to require very little maintenance. Regular maintenance involves:

- Periodically checking for leaks.
- Replacing packing as needed.

### Packing Replacement

#### Step 1:

As mentioned earlier, make a note of the proper disc position as indicated on the graduated position indicator located on the rising stem before beginning the procedure.

#### Step 2:

Shut down the pump and slowly close the upstream and downstream isolation valves to isolate the Model TDV Valve. Make sure the isolation valves are bubble tight.

#### Step 3:

Continue to open the valve (via the hand wheel) until the “stem back” meets the top of the yoke housing assembly. In this topmost position, the valve is now completely open.

#### Step 4:

Remove the flange gland (located on the cover) by loosening the two nuts and takeout the existing packing. Additionally, clean out any debris or sludge that may have accumulated in the packing cavity.

#### Step 5:

Insert a new set of packing rings (generally three rings) into the packing cavity and press them into place. To provide a tight seal, the split on the packing rings should be staggered such that they do not overlap.

#### Step 6:

Replace the flange gland and evenly tighten the flange gland nuts. Exercise caution when tightening the flange gland nuts. Excessive force can cause the stem to seize.

Packing Replacement: continued...

#### Step 7:

Adjust the disc opening to its previous position as indicated by the graduated position indicator located on the rising stem.

#### Step 8:

Open the isolation valves and restart the system.

### **CAUTION:**

If leaking occurs around the packing, evenly tighten each flange gland nut a 1/4 turn until the leaking stops.

### Internal Component Replacement

- *For internal component replacement, please contact a Stayflow design engineer.*

### **CAUTION:**

Before opening a Stayflow Model TDV Valve, always ensure the pressure inside the vessel has been reduced to atmospheric via suction or venting. Failure to do so may result in serious bodily injury.

Additionally, ensure that the media flowing in the pipeline is known and any special handling precautions are understood. Please review the Material Safety Data Sheet (MSDS) for that specific fluid.

## **Stayflow Products**

Tel: 312-428-4750 sales@stayflowproducts.com www.stayflow.com Chicago, IL

## SPARE PARTS LIST:

For the bill of materials and spare parts listing of each Model TDV Control Check Valve model, please refer to the corresponding Engineering Specification Sheet. For special or fabricated units, please refer to the certified engineering drawing for that unit.

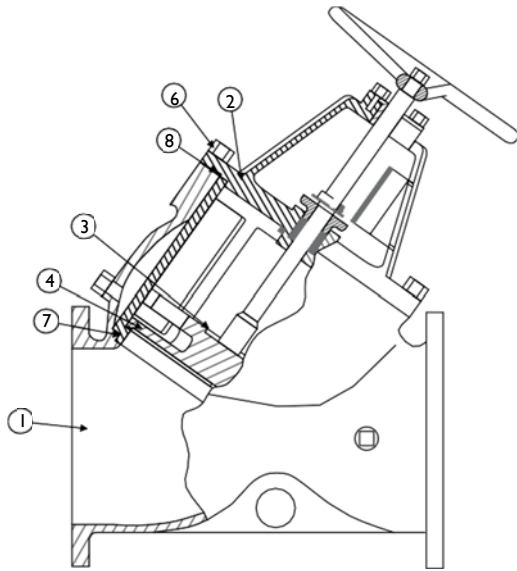

**Figure 4: Illustration of Model TDV Valve**

PARTS LIST	
No.	Model TDV Valve
1	BODY
2	COVER
3*	SPRING
4	DISC
5	DISC SEAT
6	BOLT
7	SEAT GUIDE
8*	O-RING

\* Denotes recommended spare parts

## WARRANTY:

Seller warrants each of the products and parts sold hereunder, under normal use of service, and subject to user's compliance with any operating instructions and other directions given by seller, to be free from defects in materials or workmanship for a period of one year from date of shipment from seller's plant. Seller's liability, under this warranty, shall be limited to, at the seller's option, to repairing or replacing any such defective product FOB seller's plant in Lumberton, NC, and reimbursing purchaser for shipping costs, subject to the following: (1) Timely receipt of purchaser's written notice that such products are defective. (2) Seller's written authorization to purchaser for the return of such products, (3) the return of such products to seller with shipping charges prepaid and (4) seller's inspection of and confirmation that such products are defective in materials or workmanship. If seller's inspection shows that the products returned are defective due to dirt, rust or any foreign material not attributable to seller: improper usage, over tightening on threads, abuse or incorrect assembly in the field, or other cause not due to seller's improper manufacture, seller will, subject to purchaser's written authorization, repair or replace such products at cost. Seller's factory inspection and testing reports will be made available to purchaser upon request.

THIS WARRANTY IS IN LIEU OF ANY OTHER WARRANTIES, EXPRESS OR IMPLIED, INCLUDING ANY IMPLIED WARRANTY OF FITNESS OR MERCHANTABILITY. SELLER SHALL NOT BE LIABLE FOR ANY SPECIAL, INCIDENTAL, OR CONSEQUENTIAL DAMAGES. NO REPRESENTATIVE OR SELLER HAS AUTHORITY TO MAKE ANY REPRESENTATIONS OR WARRANTIES, EXCEPT AS STATED HEREIN.