

## **PREFACE:**

This manual contains information concerning the installation, operation, and maintenance of Stayflow Baseline Butterfly Valves. To ensure efficient and safe operation of Stayflow Butterfly Valves, the instructions in this manual should be thoroughly read and understood. This manual is general in nature and is not meant to take the place of an on-site, process engineer or pipe fitter. As such, Stayflow recommends that only experienced, skilled personnel be allowed to install and maintain Stayflow Butterfly Valves. Please retain this manual in a location where it is readily available for reference.



**Figure 1: Butterfly Valve - Lug Style**

## **GENERAL INFORMATION:**

Butterfly Valves are quarter-turn valves that are installed between flanges to regulate flow in a pipeline. The disc, positioned in the center of the pipe, rotates so that the valve can be opened, closed, or partially opened.

Specific engineering design data, not contained in this manual, may be located within the BFV Specification Sheets or on certified Engineering drawings available upon request.

Prior to selection of a Stayflow Butterfly Valve the following factors must be determined:

- Material construction requirements of the Butterfly Valve.
- Design and working pressure/temperature requirements.
- Operating conditions (throttling, pressure drop, condensation, flow reversal, operation frequency, etc.).
- Service media type (liquid, gas, abrasive, corrosive, dirty, etc).
- Pipeline Media Flow-rate and Viscosity.
- Clean Start-up Pressure of the Pipeline.
- Space availability for installation.

Please contact a Stayflow Design Engineer to assist in the determination of these requirements prior to selection and purchase.

### **CAUTION:**

For large or heavy Butterfly Valves, the appropriate material handling equipment must be used to prevent injury and possible damage to the Butterfly Valve.

## **UNPACKING AND INSPECTION:**

Upon receipt of product, it is important to follow these unpacking and inspection procedures.

All Stayflow Butterfly Valves are shipped in specialized shipping containers designed to prevent damage during transportation. If external damage to the shipping container is evident upon receipt of product, please request that a representative of the shipping carrier be present before unpacking the product.

- Carefully open the shipping container, following any instructions that may be marked on the container. Remove all packing material surrounding the Butterfly Valve and carefully lift it from the container. It is recommended to keep the shipping container and all packing material for reuse in storage or reshipment.
- Visually inspect the Butterfly Valve for any signs of damage including scratches, loose parts, broken parts or any other physical damage that may have occurred during shipment. If damage is observed, immediately file a claim with the shipping carrier. Butterfly Valves that are damaged during transportation are the responsibility of the customer. For information regarding Stayflow's warranty policy, please refer to the last page of this document.

## **YOUR PIPELINE TO THE FUTURE!**

Tel: 312-428-4750 • Fax: 312-421-6327 • [sales@stayflow.com](mailto:sales@stayflow.com) •

[www.stayflowproducts.com](http://www.stayflowproducts.com)

## UNPACKING AND INSPECTION: Continued...

- Carefully remove packing material around Butterfly Valve. Inspect to make sure there are no pieces of the packaging left on the valve that could interfere with its operation.
- If the Butterfly Valve is not required to be installed immediately, it should be stored indoors in a clean, dry, consistent temperature environment. It is also recommended to utilize the original shipping container and packing materials to properly store the Butterfly Valve and keep it out of direct light. If long term storage is required, a desiccant may be necessary. This would be based upon the local, environmental storage conditions. Please consult a Stayflow Design Engineer to assist in this determination.
- When ready to install, remove any preservatives with solvent dampened cloths. Remove any loose material and protective packing material.

## INSTALLATION:

### Pre-Installation Checklist

- Ensure Working conditions (pressure and temperature) are within the specified capacity of the product being installed. Please refer to the certified Engineering drawings to assist in determining these values.
- Make sure that the construction material of the Butterfly Valve is chemically compatible with the media flowing in the pipeline.
- Inspect the Butterfly Valve's flange ends and the pipeline's mating flanges to ensure the surfaces are clean and free of defects. The pipeline should also be checked for proper alignment. Stayflow Butterfly Valves should never be utilized to realign an existing piping system.

### **CAUTION:**

Stayflow, Inc's Butterfly Valves are designed only for installation between ASME/ANSI 125 Cast Iron or 150 Ductile Iron Flanges. Although the pressure ratings are different, the bolting patterns are identical.



**Figure 2: Wafer Butterfly Valve with Actuator**

### Pre-Installation Checklist continued...

- The distance between pipe flanges should be checked to assure sufficient clearance for valve installation.
- The appropriate material handling equipment (joist and slings) should be available to lift larger units into position.

### Installation Procedure

#### Step 1:

Stayflow's Butterfly Valves are bi-directional and can be installed in a vertical or horizontal position. Check that the existing pipe sizes match the inlet and outlet sizes of the unit being installed. If pipeline strain is a concern with larger Butterfly Valves and accessories, additional support may be necessary.

#### Step 2:

Special flange gaskets are not required because the extruded portion of the seat functions as a gasket.

#### Step 3:

Make sure the Butterfly Valve is in a closed position.

#### Step 4:

Place the Butterfly Valve into position. For wafer valves, the alien holes should be aligned to the flange bolt holes ensuring that the valve is centered; the bolt holes on the lug valves should be aligned with the flange bolting.

Installation Procedure continued...

**Step 5:**

Wafer valves are placed between flanges and installed with fully threaded studs. Tapped lug valves are installed between the flanges with small cap screws on the inlet and the outlet of the valve. (See Figure 3.)

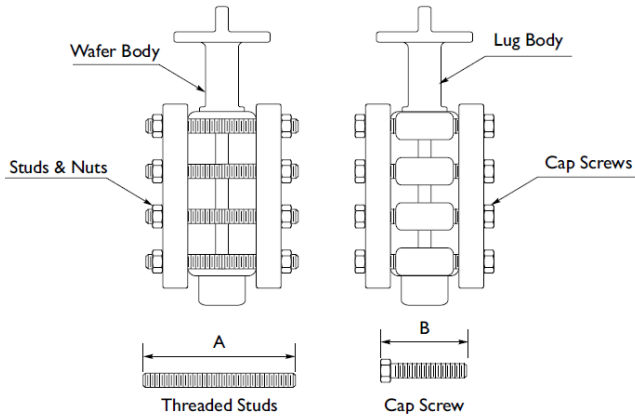

**Figure 3: Installation of Wafer and Lug Butterfly Valves**

**Step 6:**

Install lubricated flange bolts and hand tighten.

**Step 7:**

Open valve slowly to make sure that the disc does not make contact with the piping or the flanges. Close the valve.

**Step 8:**

Flange bolts should then be tightened, using a star or crisscross pattern to evenly load the bolts, in accordance with established piping standards. This is illustrated in Figure 4.

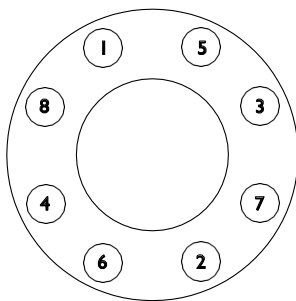

**Figure 4: Bolting Sequence Pattern**

**CAUTION:**

Excessive bolt torque may damage flanges. Please refer to established flange bolt torques for guidelines.

**OPERATION:**

Once proper installation has been successfully completed, start the system gradually, at start up as well as after shut down. This eliminates sudden shock to the butterfly valve and other equipment in the line.

Start-up Procedure:

**Step 1:**

Gradually increase system pressure until working pressure is reached.

**Step 2:**

Inspect flange connections for leaks. If leaking occurs, check for piping misalignment, that the flange bolts are properly tightened, and that the cover is properly seated.

**Step 3:**

Adjusting flow from 0° (closed) to 90° (full flow) can be done manually or automatically depending on the type of butterfly valve installed. Manual operators are available in a 10 position handle, an infinite handle, and a gear operator. Automatic operation can be achieved with a pneumatic or electric operator.

**CAUTION:**

To assist in opening and closing Butterfly Valves, gear operators are typically recommended for valves 8" and larger.

**MAINTENANCE:**

Stayflow Butterfly Valves require minimal regular maintenance. Below is a preventive checklist with recommended monthly practices:

- Adjust the valve from closed to full flow periodically

# INSTALLATION, OPERATION, AND MAINTENANCE

## MAINTENANCE: Continued...

- Visually inspect fasteners, piping, wiring, and any related equipment for problems that could hinder operation such as loosening or corrosion.
- Check the valve and around the valve for any signs of leakage.

## PARTS LIST:

For the bill of materials and parts listing of each Butterfly Valve model, please refer to the corresponding Engineering Specification Sheet. For special or fabricated units, please refer to the certified engineering drawing for that unit.

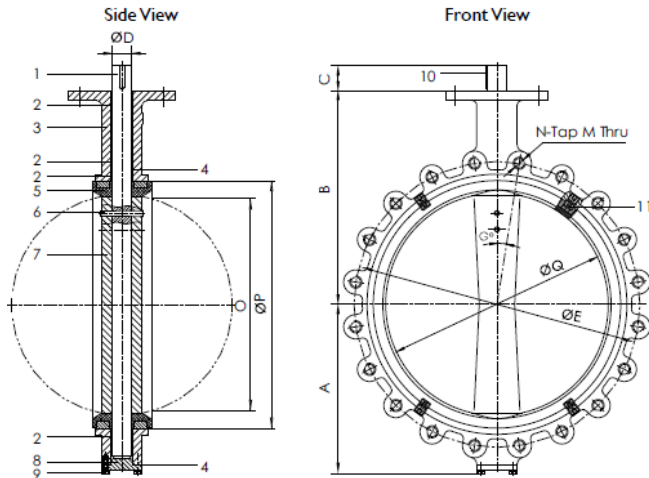

Figure 4: Illustrations of Butterfly Valve

| PARTS LIST |                 |
|------------|-----------------|
| No.        | Butterfly Valve |
| 1          | Stem            |
| 2          | Bushing         |
| 3          | Body            |
| 4          | O-Ring          |
| 5          | Seat            |
| 6          | Pin             |
| 7          | Disc            |
| 8          | End Cap         |
| 9          | Bolt            |
| 10         | Key             |
| 11         | Set Screw       |

## WARRANTY:

Seller warrants each of the products and parts sold hereunder, under normal use of service, and subject to user's compliance with any operating instructions and other directions given by seller, to be free from defects in materials or workmanship for a period of one year from date of shipment from seller's plant. Seller's liability, under this warranty, shall be limited to, at the seller's option, to repairing or replacing any such defective product FOB seller's plant in Lumberton, NC, and reimbursing purchaser for shipping costs, subject to the following: (1) Timely receipt of purchaser's written notice that such products are defective. (2) Seller's written authorization

to purchaser for the return of such products, (3) the return of such products to seller with shipping charges prepaid and (4) seller's inspection of and confirmation that such products are defective in materials or workmanship. If seller's inspection shows that the products returned are defective due to dirt, rust or any foreign material not attributable to seller: improper usage, over tightening on threads, abuse or incorrect assembly in the field, or other cause not due to seller's improper manufacture, seller will, subject to purchaser's written authorization, repair or replace such products at cost. Seller's factory inspection and testing reports will be made available to purchaser upon request.

WARRANTIES, EXPRESS OR IMPLIED, INCLUDING ANY IMPLIED WARRANTY OF FITNESS OR MERCHANTABILITY. SELLER SHALL NOT BE LIABLE FOR ANY SPECIAL, INCIDENTAL, OR CONSEQUENTIAL DAMAGES. NO REPRESENTATIVE OR SELLER HAS AUTHORITY TO MAKE ANY REPRESENTATIONS OR WARRANTIES, EXCEPT AS STATED HEREIN.