



## 1 PC REDUCED PORT THREADED END BALL VALVE

### ECONOFLO-SERIES



**Model:**  
T45-SS  
1000 WOG  
SIZE 1/4" thru 2"

### DESIGN FEATURES

- Economical Compact Design
- Ideal for gauge or drain applications
- Rugged one piece body to minimize the number of potential leak paths through body joint.
- Blow-out Proof Stem  
Stem is bottom loaded to prevent removal during operation
- Corrosion Resistant  
All 316 Stainless Steel for Superior Chemical Resistance
- Investment Cast Improves dimensional control and reduces porosity

- Safety Locking handle
- Adjustable Stem Packing
- Low Operating Torque

#### • OPTIONS •

- Carbon Steel Body
- Reverse Acting Handle
- Butterfly Handle
- Oval Handle

*Designed for the economical OEM & Industrial Markets*

## DESIGN & TECHNICAL DATA

Model: T45-SS

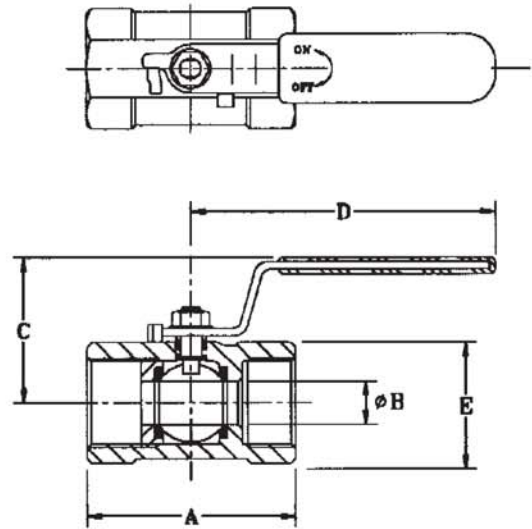
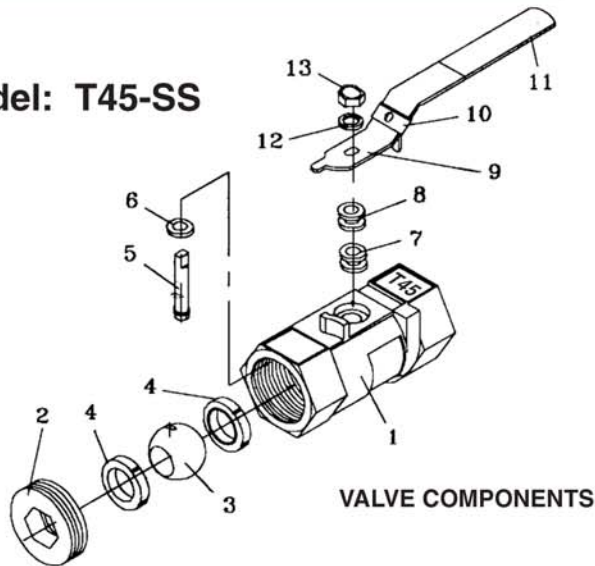

### DIMENSIONS AND WEIGHTS:

SIZE		1/4"	3/8"	1/2"	3/4"	1"	1 1/4"	1 1/2"	2"
A	in.	1.54	1.73	2.20	2.28	2.76	3.03	3.23	3.90
	mm	39.0	44.0	56.0	58.0	70.0	77.0	82.0	99.0
øB(port)	in.	0.197	0.276	0.362	0.49	0.63	0.79	0.97	1.26
	mm	5.0	7.0	9.2	12.5	16.0	20.0	24.5	32.0
C	in.	1.33	1.38	1.65	1.81	1.97	2.20	2.60	2.84
	mm	33.0	35.0	42.0	46.0	50.0	56.0	66.0	72.0
D	in.	2.38	2.95	3.50	3.50	4.17	4.17	5.04	5.04
	mm	60.5	75.0	89.0	89.0	106	106	128	128
E	in.	0.67	0.82	1.00	1.25	1.50	1.90	2.00	2.50
	mm	17.0	21.0	25.4	32.0	38.0	48.0	50.4	63.5
CV		1	2.5	5.5	10	15.5	20	37	60
Torque (in-lbf)		5	5	11	19	30	45	60	91
Weight (lbs)		0.15	0.23	0.40	0.60	0.93	1.54	1.86	2.98

Note: Torque at Line Pressure of 600 psi. •

Threaded End Connection meets ANSI B1-20-1 NPT

### PRESSURE AND TEMPERATURE DATA:

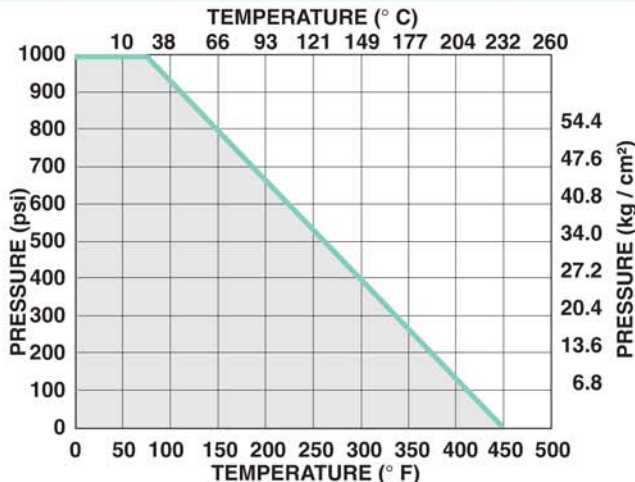

All Values Tested to MSS SP-72 at 100 psi Air under Water in OPEN and Close Positions  
ANSI / ASME B16.34 & API 598

### BILL OF MATERIALS:

ITEM	PART NAME	MATERIAL	QTY.
1	BODY	ASTM A351 GR.CF8M	1
2	SEAT RETAINER	ASTM A351 GR.CF8M	1
3	BALL	ASTM A276 TYPE 316	1
4	SEAT	PTFE	2
5	STEM	ASTM A276 TYPE 316	1
6	THRUST WASHER	RPTFE	1
7	STEM PACKING	PTFE	1
8	GLAND WASHER	ASTM A492 TYPE 304	2
9	HANDLE	ASTM A167 TYPE 304	1
10	LOCKING DEVICE*	ASTM A167 TYPE 304	1
11	LEVER SLEEVE	VINYL PLASTISOL	1
12	SPRING WASHER	ASTM A492 TYPE 304	1
13	NUT	ASTM A492 TYPE 304	1

This brochure is general in nature and manufacturer reserves the right to alter materials or to make design improvements.