



## 3PC-SS ECONOMICAL TYPE

# EconoChem Series

## Valve Features

- 3-Piece Body, Full Port Design
- 1/4" to 4" Sizes
- Threaded, Socket-Weld or Butt Weld Ends
- Body: CF8M, 316SS
- RTFE Seats or TFM
- Pressure Rating:  
1000 psi
- Temperature Range:  
(-20° F - 400° F)



### Models:

- #110 - Threaded Ends
- #120 - Socket-Weld Ends
- #130 - Butt-Weld Ends
- #190 - Grooved Ends

## Design Advantages

- ISO 5211 Direct Mounting Pad - Provides for precise shaft alignment
- 3-Piece Swing Out Design for easy maintenance
- Improved Seat Material - Extends cycle life and reduces torque
- Blowout Proof Stem
- Locking Device standard for valves with handles

**Optional:**  
A216 WCB Socket Weld Ends can be combined with Stainless Steel Bodies

**Simplicity & Performance, An Ideal Choice for Applications that Require an Economical 3PC Stainless Steel Ball Valve**

# Design and Technical Data

## Materials of Construction

ITEM	PARTS	MATERIAL
1	BODY	ASTM A351 CF8M
2	CAP	ASTM A351 CF8M
3	BALL	ASTM A351 CF8M
4	BALL SEAT	RPTFE
5	JOINT GASKET	PTFE
6	STEM	SS316
7	THRUST WASHER	PTFE
8	STEM PACKING	PTFE
9	GLAND NUT	SS304
10	HANDLE	SS430
11	STEM WASHER	SS304
12	STEM NUT	SS304
13	PLASTIC COVER	PLASTIC
14	LOCK WASHER	SS304
15	BOLT	SS304
16	SPRING WASHER	SS304
17	HEX NUT	SS304
18	STOP PIN	SS304

100 Series valves comply with MSS-SP 72.

All valves are tested in accordance with MSS-SP 72.

Threaded End Connections meet ASME/ANSI B1.20.1 NPT.

Socket Weld End Connections meet ASME/ANSI B16.11

100 Series Valves carried CE Marking

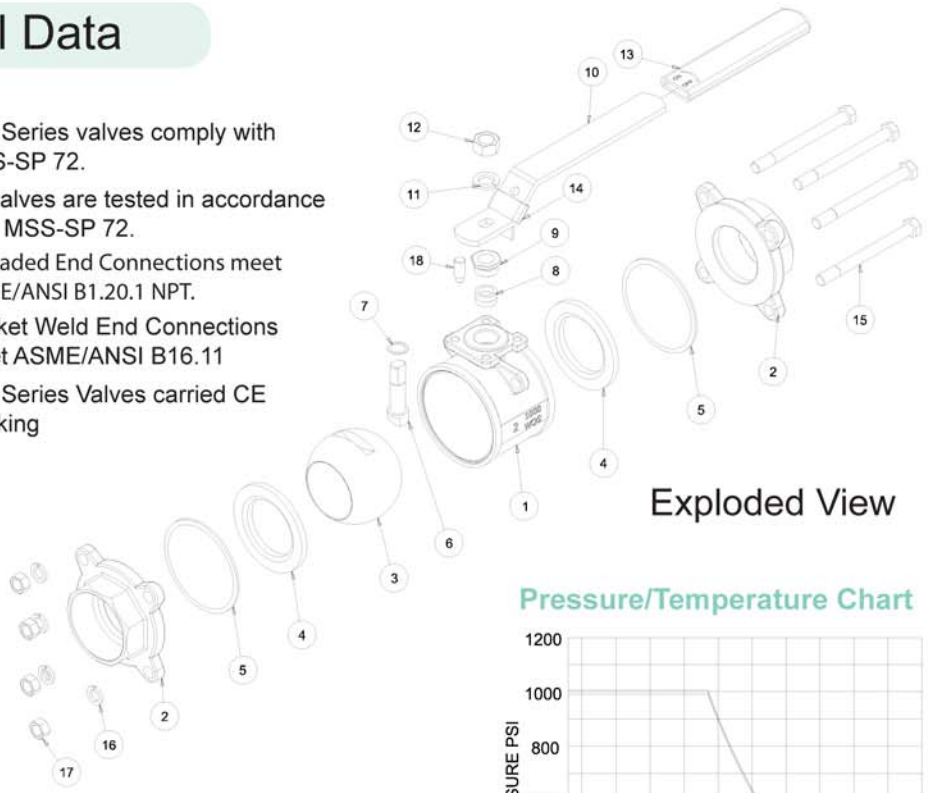

Exploded View

Steam Rating 150 PSI WSP  
250 PSI available with SuperTek III seats.

Vacuum service to 20 microns

## Pressure/Temperature Chart

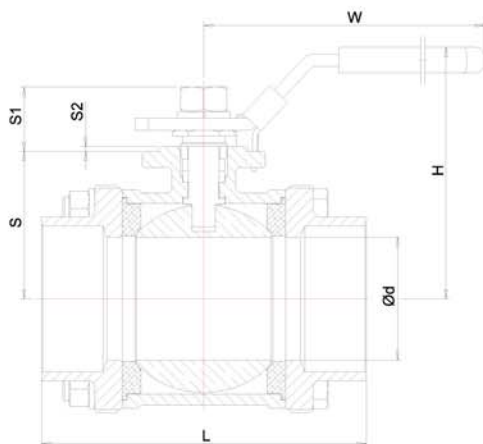
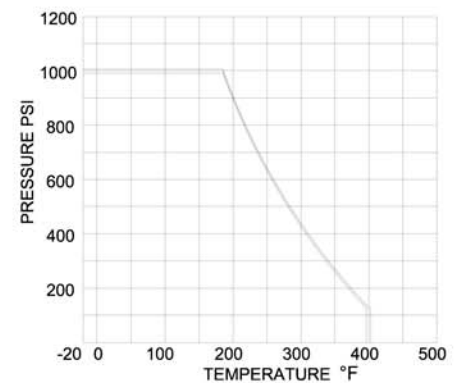

## Models 100 Series

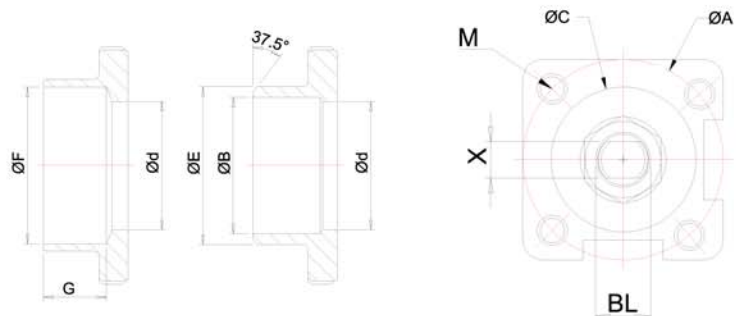

## Dimensions and Weights

SIZE	ØA	ØB	BL	ØC	Ød	ØE	ØF	G	H	L	M	S	S1	S2	W	X	Cv	Torque	ISO	Weight
																		In-Lb	Pattern	Lb
1/4"	1.42	0.47	5/16"	--	0.46	0.71	0.56	0.51	2.17	2.29	M5	1.04	0.52	--	3.74	0.197	8	35	F03	0.75
3/8"	1.42	0.55	5/16"	--	0.50	0.71	0.69	0.50	2.17	2.29	M5	1.04	0.52	--	3.74	0.197	10	35	F03	0.84
1/2"	1.42	0.67	5/16"	--	0.59	0.87	0.85	0.52	2.36	2.44	M5	1.20	0.62	--	3.74	0.197	18	47	F03	1.1
3/4"	1.42	0.89	3/8"	--	0.79	1.08	1.07	0.68	2.48	2.99	M5	1.30	0.72	--	4.33	0.256	42	82	F03	1.8
1"	1.65	1.10	7/16"	1.21	0.98	1.32	1.33	0.71	3.11	3.35	M5	1.56	0.85	0.08	5.31	0.315	74	90	F04	2.6
1-1/4"	1.65	1.32	7/16"	1.21	1.26	1.73	1.68	0.80	3.39	3.94	M5	1.71	0.91	0.08	5.31	0.315	130	124	F04	4.4
1-1/2"	1.97	1.69	1/2"	1.42	1.50	1.97	1.92	0.87	3.70	4.53	M6	2.05	0.98	0.08	6.50	0.354	210	185	F05	5.5
2"	1.97	2.09	1/2"	1.42	1.97	2.42	2.41	0.96	4.06	5.20	M6	2.44	0.91	0.08	6.50	0.354	370	300	F05	8.2
2-1/2"	2.76	2.56	3/4"	2.20	2.56	2.99	3.03	1.30	5.24	6.50	M8	3.03	1.62	0.08	8.46	0.472	660	440	F07	16.3
3"	4.02	3.15	3/4"	2.80	3.15	3.62	3.52	1.44	5.67	7.20	M10	3.54	1.56	0.06	8.46	0.472	928	770	F10	28.2
4"	4.02	3.94	1"	--	3.94	4.53	4.55	1.67	6.97	9.11	M10	4.33	1.85	--	12.8	0.630	1710	1400	F10	50.7



sales@stayflowproducts.com 312-428-4750 www.stayflowproducts.com

Due to continuous development & improvement of our product range, we reserve the right to alter the dimensions and technical data included in this brochure