



KINGTRON SERIES PETROCHEMICAL APPLICATIONS

3-PIECE CLASS 2500 FORGED STEEL BALL VALVES

Model #: EXTENDED SOCKET WELD X SOCKET WELD ENDS, 6000 PSI (414 BAR) W.O.G., 1/4" TO 1 1/2": FULL PORT, 2": T336 STANDARD PORT, ISO 5211 MOUNTING PAD, NACE MR-0175.

FEATURES:

- Forged steel body construction secures Class 2500/6000 psi working pressure rating.
- LF2 valve body & end caps for low-temperature applications.
- Special design of extended socket weld end facilitates heat dissipation during welding. No prior disassembly of valve is required therefore welding installation process is shortened.
- Use of body O-ring and body joint gasket double secures NO LEAKAGE.
- Live-loaded packing gland for self-adjustment of stem packing compression.
- Rugged lockable lever handles for safety and long service life.
- Body O-rings are placed ahead of the body cap threads, providing a tight seal and protection of threads from flow media.
- Gland bolts allow for easy packing adjustment without handle removal.
- Pressure equalizing seats & bottom-loaded blow-out proof stem.
- Vented ball equalizes pressure between the body cavity and the flow stream to prevent seat damage due to thermal cycling.
- Fully compliance with ASME/ANSI B16.34 & En12516-1.
- Socket weld ends complied with ANSI B16.11 & EN 12760.
- Tested according to API 598.



Material List:

NO.	PARTS	S336-LF2	S336-A105
1	BODY	ASTM A350-LF2	ASTM A105
2	END CAP	ASTM A350-LF2	ASTM A105
3	SEAT	PEEK	PEEK
4	GASKET	PTFE	PTFE
5	BALL	ASTM A351-CF8M/316	ASTM A351-CF8M/316
6	THRUST WASHER	PEEK	PEEK
7	STEM	ASTM A276-316	ASTM A276-316
8	STEM PACKING	PTFE	PTFE
9	GLAND	AISI 304	AISI 304
10	HANDLE	CARBON STEEL	CARBON STEEL
11	DISC WASHER	AISI 301	AISI 301
12	HANDLE NUT	CARBON STEEL	CARBON STEEL
13	GLAND FLANGE	CARBON STEEL	CARBON STEEL
14	GLAND BOLT	AISI 304	AISI 304
15	BODY O-RING	VITON	VITON
16	STEM O-RING	VITON	VITON
17	ANTI-STATIC	STAINLESS STEEL	STAINLESS STEEL

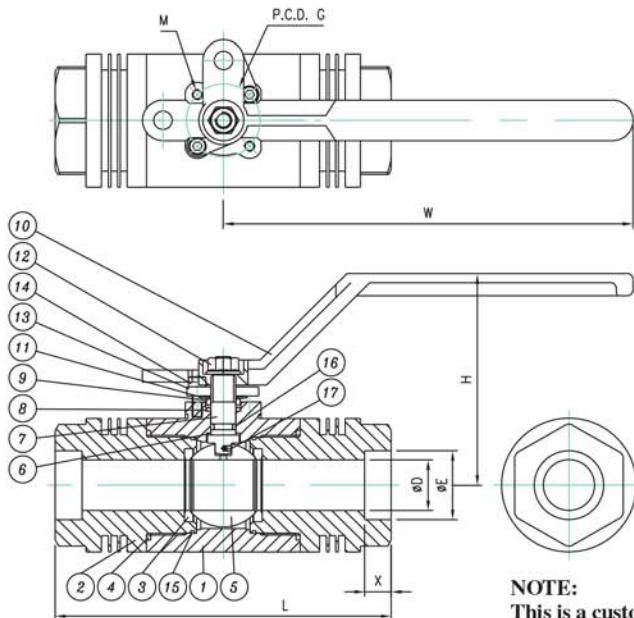

NOTE:
This is a custom order item. Consult factory for price and availability.

DIMENSIONS:

SIZE	ØD		ØE		L		H		W		X		ØG		M	Torque in-lb	
	in	DN	in	mm	in	mm	in	mm	in	mm	in	mm	in	mm			
1/4"	8	0.37	9.5	0.56	14.2	4.61	117	3.15	80.0	6.30	160	0.39	10	1.42	36	M5	300
3/8"	10	0.37	9.5	0.69	17.6	4.61	117	3.15	80.0	6.30	160	0.39	10	1.42	36	M5	300
1/2"	15	0.49	12.5	0.86	21.8	4.61	117	3.15	80.0	6.30	160	0.39	10	1.42	36	M5	400
3/4"	20	0.79	20	1.07	27.2	5.98	152	3.90	99.0	7.87	200	0.51	13	1.42	36	M5	712
1"	25	0.98	25	1.33	33.9	6.46	164	4.09	104	7.87	200	0.51	13	1.42	36	M5	1500
1 1/2"	40	1.50	38	1.92	48.8	7.87	200	5.03	128	9.84	250	0.51	13	1.97	50	M6	2400
2"	50	1.50	38	2.41	61.2	8.07	205	5.03	128	9.84	250	0.64	16.2	1.97	50	M6	3200

OPTIONS:

- 17-4PH (ASTM A564 Type 630) Stem.
- F: Fire-safe per API 607, including graphite gasket, graphite stem packing, & post-fire metal-to-metal seal.
- HSN (HNBR) stem O-ring & body O-ring, PTFE body O-ring, -Carbon 25% filled PTFE thrust washer, stem packing and gasket

Pressure-Temperature Ratings

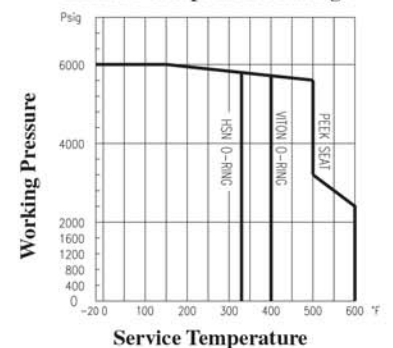



KINGTRON SERIES PETROCHEMICAL INDUSTRIES

3-PIECE CLASS 2500 FORGED STEEL BALL VALVES

Model #: EXTENDED SOCKET WELD X THREADED ENDS, 6000 PSI (414 BAR) W.O.G., 1/4" TO 1 1/2";
ST336 FULL PORT, 2": STANDARD PORT, ISO 5211 MOUNTING PAD, NACE MR-0175.

FEATURES:

- Forged steel body construction secures Class 2500/6000 psi working pressure rating.
- LF2 valve body & end caps for low-temperature applications.
- Special design of extended socket weld end facilitates heat dissipation during welding. No prior disassembly of valve is required therefore welding installation process is shortened.
- Use of body O-ring and body joint gasket double secures NO LEAKAGE.
- Live-loaded packing gland for self-adjustment of stem packing compression.
- Rugged lockable lever handles for safety and long service life.
- Body O-rings are placed ahead of the body cap threads, providing a tight seal and protection of threads from flow media.
- Gland bolts allow for easy packing adjustment without handle removal.
- Pressure equalizing seats & bottom-loaded blow-out proof stem.
- Vented ball equalizes pressure between the body cavity and the flow stream to prevent seat damage due to thermal cycling.
- Fully compliance with ASME/ANSI B16.34 & En12516-1.
- Socket weld ends complied with ANSI B16.11 & EN 12760.
- Tested according to API 598.



Material List:

NO.	PARTS	ST336-LF2	ST336-A105
1	BODY	ASTM A350-LF2	ASTM A105
2	SW END CAP	ASTM A350-LF2	ASTM A105
3	SEAT	PEEK	PEEK
4	GASKET	PTFE	PTFE
5	BALL	ASTM A351-CF8M/316	ASTM A351-CF8M/316
6	THRUST WASHER	PEEK	PEEK
7	STEM	ASTM A276-316	ASTM A276-316
8	STEM PACKING	PTFE	PTFE
9	GLAND	AISI 304	AISI 304
10	HANDLE	CARBON STEEL	CARBON STEEL
11	DISC WASHER	AISI 301	AISI 301
12	HANDLE NUT	CARBON STEEL	CARBON STEEL
13	GLAND FLANGE	CARBON STEEL	CARBON STEEL
14	GLAND BOLT	AISI 304	AISI 304
15	BODY O-RING	VITON	VITON
16	STEM O-RING	VITON	VITON
17	NPT END CAP	ASTM A352-LCC	ASTM A216-WCB
18	ANTI-STATIC	STAINLESS STEEL	STAINLESS STEEL

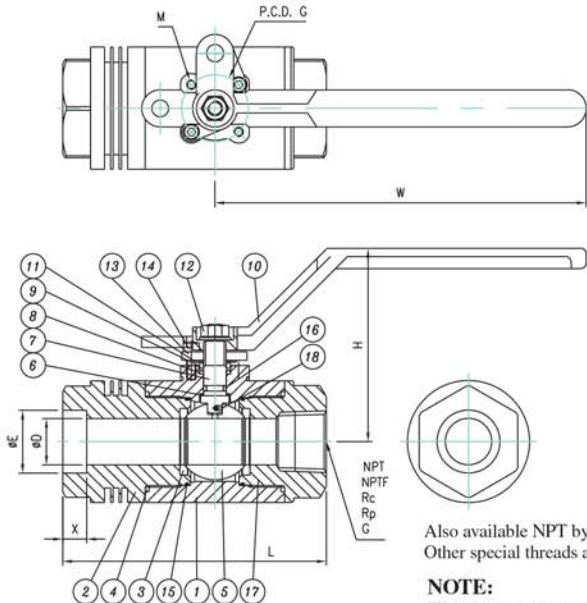

Also available NPT by NPT model no. T336
Other special threads are also available.

NOTE:
This is a custom order item. Consult factory for price and availability.

DIMENSIONS:

SIZE		øD		øE		L		H		W		X		øG		M	Torque in-lb
in	DN	in	mm	in	mm	in	mm	in	mm	in	mm	in	mm	in	mm		
1/4"	8	0.37	9.5	0.56	14.2	3.96	101	3.15	80.0	6.30	160	0.39	10	1.42	36	M5	300
3/8"	10	0.37	9.5	0.69	17.6	3.96	101	3.15	80.0	6.30	160	0.39	10	1.42	36	M5	300
1/2"	15	0.49	12.5	0.86	21.8	4.17	106	3.15	80.0	6.30	160	0.39	10	1.42	36	M5	400
3/4"	20	0.79	20	1.07	27.2	5.12	130	3.90	99.0	7.87	200	0.51	13	1.42	36	M5	712
1"	25	0.98	25	1.33	33.9	5.59	142	4.09	104	7.87	200	0.51	13	1.42	36	M5	1500
1 1/2"	40	1.50	38	1.92	48.8	6.73	171	5.03	128	9.84	250	0.51	13	1.97	50	M6	2400
2"	50	1.50	38	2.41	61.2	7.09	180	5.03	128	9.84	250	0.64	16.2	1.97	50	M6	3200

OPTIONS:

- 17-4PH (ASTM A564 Type 630) Stem.
- F: Fire-safe per API 607, including graphite gasket, graphite ste packing, & post-fire metal-to-metal seal.
- HSN (HNBR) stem O-ring & body O-ring, PTFE body O-ring,
- Carbon 25% filled PTFE thrust washer, stem packing and gasket

Pressure-Temperature Ratings

