

STAYFLOW

Flanged & Wafer Segmented Ball Valves

SENTINEL SERIES

**Engineered Valves For Severe Service Applications
where precise control is required**

Models:

RV-150
RV-300
RV-600
Metal or Soft Seated

Size Range:

1" - 24"

Pressure Rating :

Flanged End : 150#, 300#, 600#
Wafer Type : 150#, 300#



Standard Body Materials :

Carbon & Stainless Steel
Options: 304, 317, 2205

Stayflow's Sentinel Series, rugged unibody construction minimizes the number of potential leak paths. Available in flanged or flangeless end connections.



**Ideal Valve Design for Clean or Dirty Liquids, Gases and
Fibrous Suspension Applications**

Stayflow's Sentinel series is a quarter turn control valve generally recommended for throttling service. Our segmented ball valve combines globe control flow characteristics with the efficiency of the rotary type ball valve. The segmented ball is a V-notch design with strong cutting force and a self-cleaning design, especially suitable for control of media containing fiber and tiny solids. Segmented ball valves were designed for the pulp and paper industry. Through research and development, segmented ball valves extend to other industrial markets such as petro-chemical, petroleum, chemical, fiber, power, metallurgy, pharmacy, environmental protection and many more flow control applications.

DESIGN FEATURES

Precise contouring of the V-notch provides excellent control characteristics for an extensive variety of flow applications. An ideal control performance is designed into the geometry of the ball for critical management of flow. A locked ball-to-shaft connection ensures no lost motion during critical control.

Splined connection between the shaft and ball ensures precise control and low hysteresis.

Streamlined flow passage provides maximum efficiency and minimizes erosion inside the valve body.

Detachable seat retainer design provides easy access to trim parts of the valves through inlet of valve by simply removing the screws of retainer allowing for easy maintenance. Repair kits are available for all valve designs.

Superior trunnion bearing technology is engineered for excellent abrasion resistance.

Rugged self-adjusting metal seated option is ideally suited for higher temperature applications or slurries. Spring loaded seat maintains constant contact with the ball, providing enhanced sealing performance.

Shearing action between ball and seat promotes smooth, non-clogging operation, perfect for fibrous or slurry applications.

Optional "Chem-Tek" is a special material impregnated directly into all valve wetted surfaces that helps prevent the build up of scale commonly found in green liquor and other severe applications.

Sentinel Series Control Valves

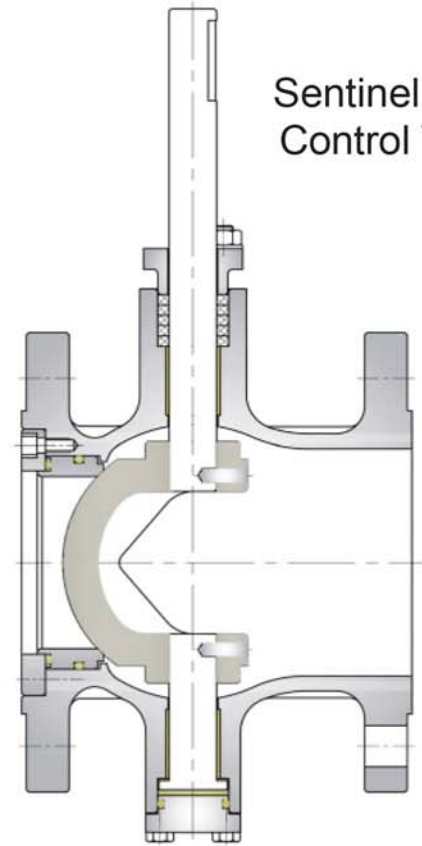

A locked ball-to-shaft connection ensures no lost motion for critical control.



BILL OF MATERIALS

Exploded View Sentinel Series

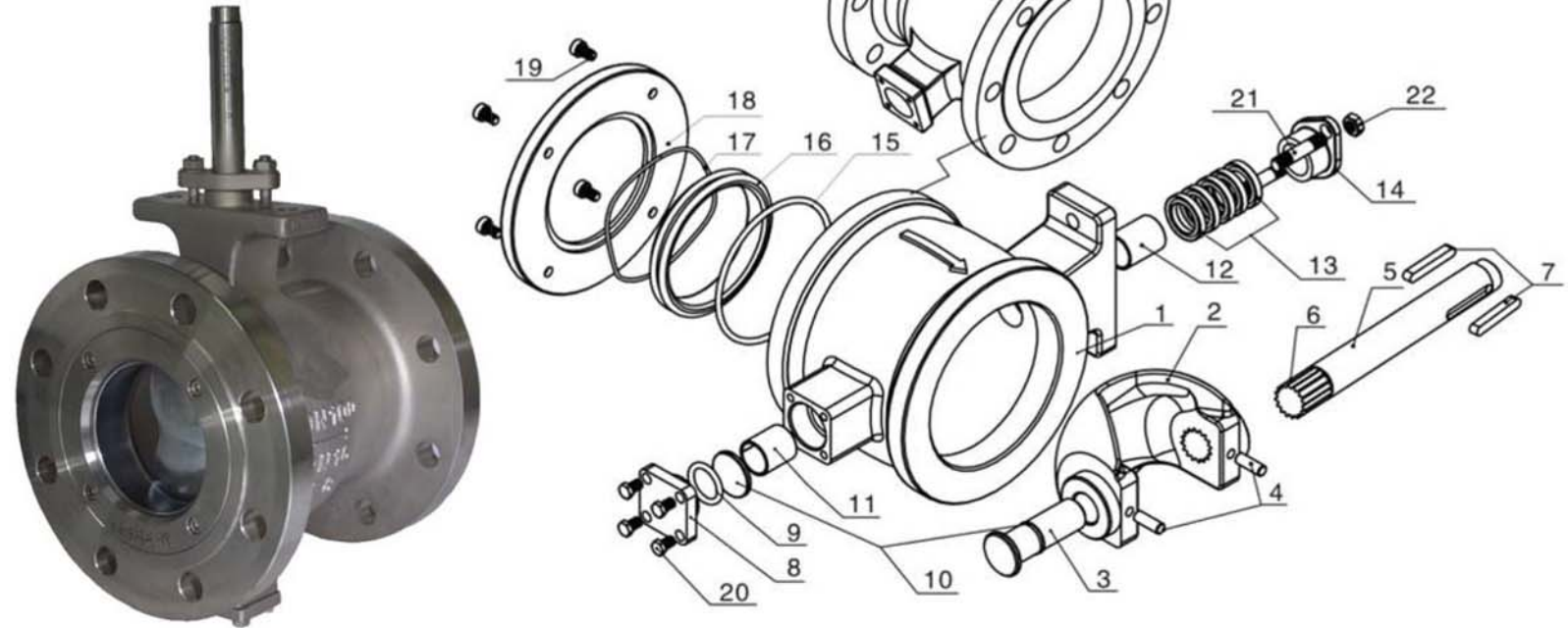

No.	Name	Quantity	Material
1	Body	1	WCB, CF8, CF8M, 317, 2205 Duplex
2	Ball	1	CF8, CF8M, Hard Chrome Plating or Stellite Surfacing
3	Lower Shaft	1	17-4PH, SS316L
4	Cylindrical Pin	2	SS304, SS316
5	Upper Shaft	1	17-4PH, SS316L
6	Spline	1	17-4PH, SS316
7	Flat Key	2	SS304, Carbon Steel
8	Blind Flange	1	CF8, CF8M
9	O-Ring	1	VITON, Graphite
10	Gasket	1 each	PTFE, Graphite
11	Self Lubricating Bearing	1	Composite Material
12	Self Lubricating Bearing	1	Composite Material
13	Packing	1 set	PTFE, Graphite
14	Gland	1	CF8
15	O-Ring	1	Viton, Graphite
16	Seat	1	PTFE, Devlon, SS304, SS316, Hard Chrome Plating or Stellite Surfacing
17	Wave Spring	1	SS316
18	Retainer	1	Carbon Steel, SS304, SS316
19	Socket Head Screw	4	A193 B7, A193 B8
20	Hexgon Screw	4	A193 B7, A193 B8
21	Stud	2	A193 B7, A193 B8
22	Hexagon Nut	2	A194 2H, A194 8

- End Connection: Wafer 1" through 10", MFR standard. Flanged End 1" through 24"
- Face to Face Dimensions: IEC/DIN 534-3-2 or ISA S75.04
- Nominal Pressure Rating: Class 150, Class 300, Class 600
- Working Temperature: -20 - 320 °F, optional -29 - 842 °F
Consult factory for higher temperature services
- Pressure Test: Each valve undergoes hydraulic test with 1.5 times pressure rating as shell test, seat tightness test is according to ANSI FCI 70.2
- Leakage Rate: ANSI FCI 70.2 Class VI for Soft Seat;
1% of maximum allowable leakage of ANSI FCI 70.2 Class IV for Metal Seat;
Consult factory for higher tightness class requirements.
For control valves with bubble tight shut off capability, consult Tech Bulltin 120.
- International Bolting: PN10, 16, 25 and 40, with DIN 10, 16, 25 and 40; JIS 10, 16 and 20 bolting.
Options are also available in our ANSI take-out CP series, C/F.

VARIOUS SEAT CONSTRUCTION

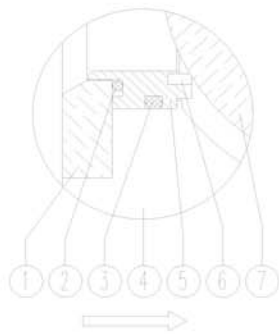

Seat A

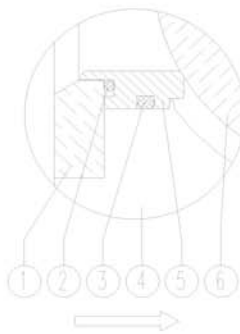

Seat B

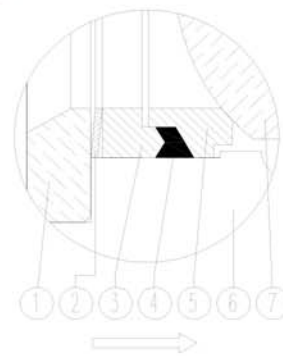

Seat C

Seat A: Soft Seat

No.	Parts	Temperature Range
1	Retainer	-20 - 320 °F (-29 - 160 °C)
2	Spring	
3	O-Ring	
4	Valve Body	
5	Seat Retainer	
6	Seat Seal	
7	Ball	

Seat B: Standard Metal Seat

No.	Parts	Temperature Range
1	Retainer	-20 - 356 °F (-29 - 180 °C)
2	Spring	
3	O-Ring	
4	Valve Body	
5	Seat	
6	Ball	

Seat C: High Temperature Metal Seat

No.	Parts	Temperature Range
1	Retainer	-20- 842 °F (-29 - 450 °C)
2	Spring	
3	Plunge Ring	
4	Graphite Ring	
5	Metal Seat	
6	Valve Body	
7	Ball	

VARIOUS TRIM DESIGNS FOR LOW CV & NOISE APPLICATIONS



When the flow rate of the application is too low and calling for valves with very low flow capacity for throttling that a standard 3/4" or 1" trim of the segment ball valves can not manage to achieve, special low Cv trim design is available, engineered as per specific Cv requirements to provide precise throttling performance, which particularly meets the control requirements of additives and coatings in paper making industry.



Low noise trim provides very good solution to applications subject to excessive noise levels with conventional trim, especially for control systems handling gas, steam and other applications that require a limited level of noise. Meanwhile, it can also prevent the potential risk of damage to piping system and affect life cycle and control performance of the control valve resulting from cavitation during controlling of water and other liquids under high differential pressure.

MAXIMUM ALLOWABLE DIFFERENTIAL PRESSURE AND TORQUES

Valve Size		Class 150										Class 300									
		Max Shut Off Differential Pressure				Max Control Differential Pressure				Maximum Torque *		Max Shut Off Differential Pressure				Max Control Differential Pressure				Maximum Torque *	
		Wafer		Flanged		Wafer		Flanged				Wafer		Flanged		Wafer		Flanged			
NPS	DN	bar	psi	bar	psi	bar	psi	bar	psi	NM	In-Lbs	bar	psi	bar	psi	bar	psi	bar	psi	NM	In-Lbs
1"	25	20	290	20	290	15	217	15	217	25	221	50	725	40	580	35	507	35	507	48	425
1 1/4"	32	20	290	20	290	15	217	15	217	25	221	50	725	40	580	35	507	35	507	55	487
1 1/2"	40	20	290	20	290	15	217	15	217	30	266	50	725	40	580	35	507	35	507	60	531
2"	50	20	290	20	290	15	217	15	217	35	310	50	725	40	580	35	507	35	507	70	620
2 1/2"	65	20	290	20	290	15	217	15	217	60	531	50	725	40	580	35	507	35	507	140	1239
3"	80	20	290	20	290	15	217	15	217	80	708	50	725	40	580	35	507	35	507	224	1983
4"	100	16	232	16	232	12	174	12	174	140	1239	40	580	40	580	25	362	25	362	315	2788
5"	125	16	232	16	232	12	174	12	174	160	1416	40	580	40	580	25	362	25	362	480	4248
6"	150	16	232	16	232	12	174	12	174	220	1947	40	580	40	580	25	362	25	362	930	8231
8"	200	16	232	16	232	12	174	12	174	350	3098	35	507	40	580	25	362	25	362	1830	16197
10"	250	14	203	14	203	10	145	10	145	660	5841	35	507	40	580	20	290	20	290	3125	27659
12"	300	/	/	14	203	/	/	10	145	1200	10621	/	/	40	580	/	/	20	290	4000	35403
14"	350	/	/	12	174	/	/	8	116	1700	15046	/	/	40	580	/	/	20	290	6120	54167
16"	400	/	/	12	174	/	/	8	116	2600	23012	/	/	40	580	/	/	20	290	8030	71072
18"	450	/	/	10	145	/	/	6	87	3500	30978	/	/	40	580	/	/	20	290	12000	106209
20"	500	/	/	10	145	/	/	6	87	3800	33633	/	/	30	435	/	/	10	145	15000	132761
24"	600	/	/	8	116	/	/	4	58	6000	53105	/	/	30	435	/	/	10	145	20500	181440

*Valve Torques Are for Metal Seated B Style Valves with MC-pulp Medium
 For Soft Seated Valve Torque, Deduct 10% off the Chart
 For Clean Liquid Media, Deduct 20% off the Chart

Consult Factory for Other Media.

Rated Cv

VALVE SIZE		CV
NPS	DN	
1"	25	27
1 1/4"	32	47
1 1/2"	40	70
2"	50	135
2 1/2"	65	210
3"	80	390
4"	100	560
5"	125	790
6"	150	1130
8"	200	1860
10"	250	2900
12"	300	4320
14"	350	6640
16"	400	8000
18"	450	10000
20"	500	12200
24"	600	17270

Typical Inherent Equal Percentage Flow Characteristics

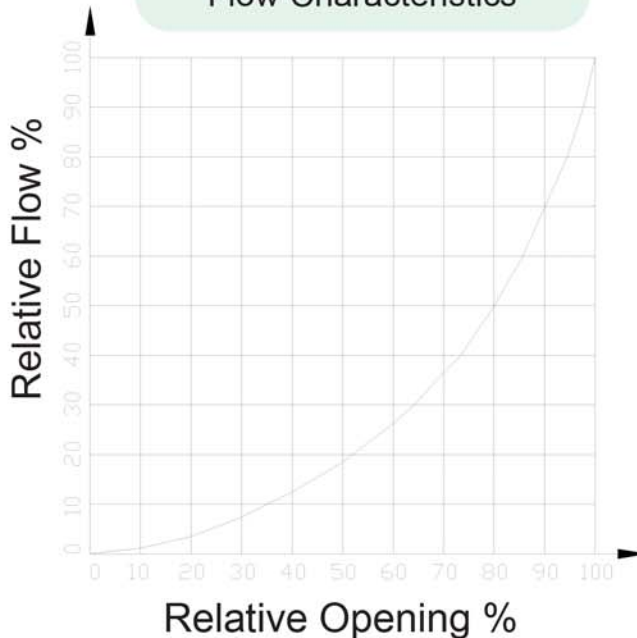

Important Information Required to size control valves:

1. Type of Media, ie Liquid, Gas or Steam
2. What Type of Calculation
 - a, Cv required given the Flow Rate Through the Valve
 - b, Flow Rate given the Cv
3. Flow Rate, GPM, PPH (Lb/H), SCFM
4. Inlet Pressure of Media to Valve (PSIG)
5. Outlet Pressure of Media from Valve (PSIG)
6. Inlet Temperature of Media at Valve
7. Specific Gravity of Media at Valve
8. Media Vapor Pressure (PSIA)
9. Media Critical Pressure
10. Pipe Size Upstream of Valve
11. Pipe Size Downstream of Valve

Cv: The volume of water in United States gallons per minute that will pass through a given valve opening with a pressure drop of 1 pound per square inch. (water at temp = 60 deg.f)

Capacity: Rate of flow through a valve under stated conditions. "Rated Capacity" is the flow through a valve in the full open position.

Control Valve: A final controlling element (through which a fluid passes) which adjusts the size of the flow passage as directed by a signal from a controller to modify the rate of flow of the fluid.

Equal Percentage Flow Characteristic: An inherent flow characteristic which, for equal increments of rated travel, will ideally give equal percentage changes of the existing flow.

Rangeability: It is the ratio of the maximum to the minimum controllable flow coefficients(Cv). A control valve that still does a good job of controlling when flow increases to 100 times the minimum controllable flow has a rangeability of 100 : 1.

Turndown: Turndown is a simple ratio of the maximum to the minimum controllable flow rate. For example, if the minimum flow rate were 10 gpm and maximum flow rate were 100 gpm, the turndown would be 10:1.

PRESSURE TEMPERATURE RATING

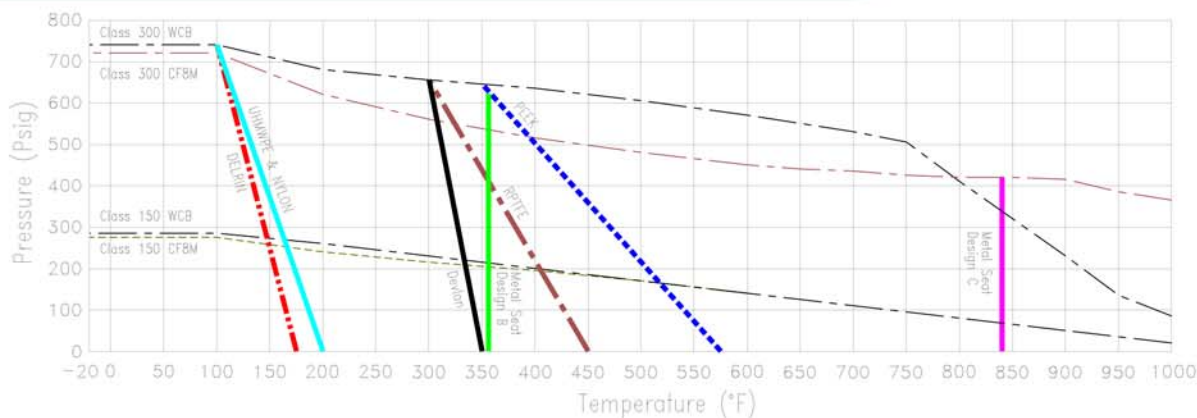

Seat Design B is standard metal seat with a temperature limit of 356 °F.
 Seat Design C is optional metal seat with a temperature limit of 842 °F.

WCB is not recommended for prolonged use above 800 °F

Stayflow's Manufacturing Partner

Linuo Flow Control Technology Co. Is a highly certified Company with over 15 years manufacturing segmented, trunnion ball valves, knife gate, gate, globe and check valves.

CERTIFICATIONS



API 6D



CE / PED



EAC



ISO 9001



API 607 6th

Actuator Options



Rack & Pinion
Pneumatic Type



Spring-Diaphragm
Rotary Type



Piston
Type Design



Extended Range Series, Torque Range
from 300,146 to 1,565,201 in-lb



Electric Actuator



Manual Worm Gear





Valve Drawings Are Shown with Special Order Tall Stems with Optional Key Shaft.

Request Drawings for Double-D or Spline Shaft Connections.

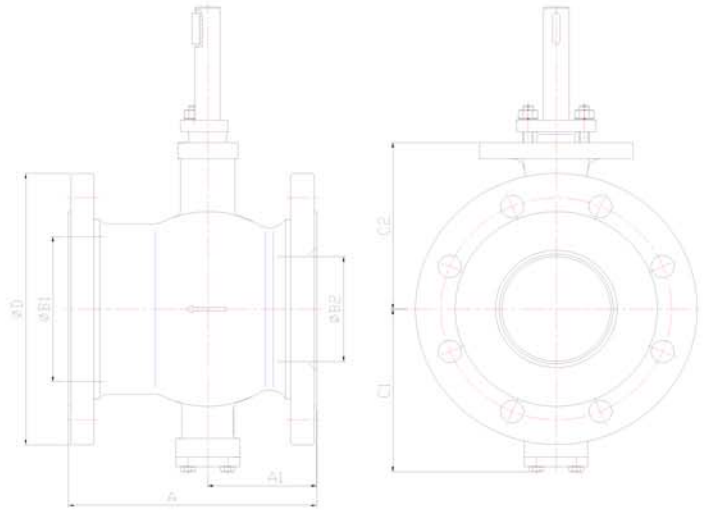

FLANGED TYPE, CLASS 150

SIZE		A	A1	B1	B2	C1	C2	D	Weight Lbs
NPS	DN								
1"	25	4.02	2.24	1.50	0.79	3.46	3.07	4.25	9
1 1/4"	32	4.02	2.05	1.89	0.98	3.46	3.15	4.62	12
1 1/2"	40	4.50	2.56	2.05	1.26	3.46	3.35	5.00	13
2"	50	4.88	2.64	2.36	1.65	3.94	3.66	6.00	17
2 1/2"	65	5.71	3.35	3.15	2.09	4.65	4.41	7.00	21
3"	80	6.50	3.64	3.90	2.87	4.76	4.69	7.50	31
4"	100	7.62	4.41	4.65	3.39	5.24	5.16	9.00	47
5"	125	8.39	4.65	5.43	4.21	6.02	5.91	10.00	51
6"	150	9.00	4.88	6.57	5.04	7.09	7.01	11.00	82
8"	200	9.56	4.80	8.27	6.38	7.87	8.07	13.50	128
10"	250	11.69	5.83	10.39	8.11	9.65	9.45	16.00	187
12"	300	13.31	6.30	12.20	9.29	11.42	10.59	19.00	289
14"	350	15.75	7.36	14.37	11.57	13.78	12.95	21.00	439
16"	400	15.75	7.48	16.14	13.39	16.14	15.00	23.50	761
18"	450	20.47	9.76	18.11	14.96	16.85	16.85	25.00	1124
20"	500	23.62	11.81	20.31	16.54	19.69	19.29	27.50	1338
24"	600	26.77	12.60	24.41	19.69	22.05	22.05	32.00	1587

All (1" - 16") Flanged End Valve's take-outs meet ISA S75.04

FLANGED TYPE, CLASS 300

SIZE		A	A1	B1	B2	C1	C2	D	Weight Lbs
NPS	DN								
1"	25	4.17	2.24	1.50	0.79	3.46	3.19	4.88	9
1 1/4"	32	4.17	2.13	1.65	0.98	3.46	3.46	5.25	12
1 1/2"	40	4.80	2.72	1.97	1.26	3.46	3.35	6.12	13
2"	50	4.88	2.44	2.36	1.50	4.13	3.94	6.50	24
3"	80	6.50	3.25	3.90	2.68	5.35	5.31	8.25	49
4"	100	7.62	4.02	4.65	3.15	5.71	5.59	10.00	71
6"	150	9.00	4.51	6.57	4.92	8.07	7.83	12.50	137
8"	200	9.56	4.39	8.27	6.30	8.66	8.62	15.00	198
10"	250	11.69	5.31	10.39	7.87	10.55	10.94	17.50	331
12"	300	13.31	5.98	12.20	9.06	11.42	11.54	20.50	485
14"	350	15.75	7.28	14.37	11.42	13.78	13.98	23.00	683

All (2" - 14") Flanged End Valve's take-outs meet ISA S75.04

WAFER TYPE, CLASS 150

SIZE		A	A1	B1	B2	C1	C2	D	Weight Lbs
NPS	DN								
1"	25	2.44	1.06	1.50	0.79	3.46	2.95	2.68	6
1 1/4"	32	2.44	0.87	1.73	0.98	3.46	3.15	3.07	7
1 1/2"	40	2.44	0.87	1.97	1.26	3.46	3.35	3.35	8
2"	50	2.95	1.22	2.36	1.50	3.94	3.54	3.94	9
2 1/2"	65	3.54	1.38	2.95	2.09	4.65	4.33	4.72	13
3"	80	3.94	1.57	3.90	2.68	4.76	4.69	5.12	17
4"	100	4.53	1.77	4.65	3.15	5.24	5.16	6.22	24
5"	125	5.08	2.01	5.51	4.21	6.02	5.91	7.24	34
6"	150	6.30	2.56	6.57	4.92	7.09	7.01	8.50	55
8"	200	7.87	3.23	8.27	6.30	7.87	8.07	10.55	86
10"	250	9.45	3.58	10.39	7.87	9.65	9.45	12.68	141

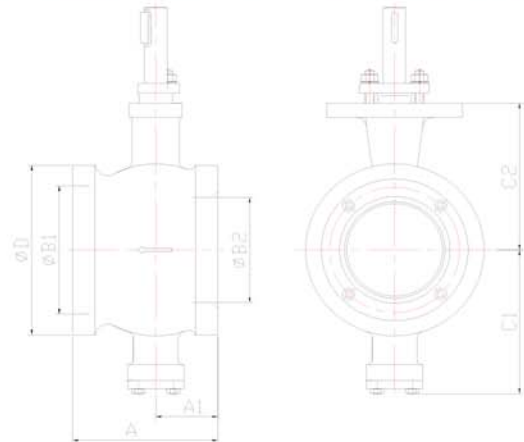

TYPICAL VALVE MOUNTING INFORMATION (w/ standard bracket & coupler)

SIZE		S		h		d1			d2			H	
NPS	DN	mm	inch	mm	inch	mm	inch	ISO	mm	inch	ISO	mm	inch
1"	25	17	0.669	17	0.669	70	2.76	F07				90	3.54
1 1/2"	40	22	0.866	22	0.866	70	2.76	F07	102	4.02	F10	90	3.54
2"	50	22	0.866	22	0.866	70	2.76	F07	102	4.02	F10	90	3.54
2 1/2"	65	22	0.866	22	0.866	70	2.76	F07	102	4.02	F10	90	3.54
3"	80	22	0.866	22	0.866	70	2.76	F07	102	4.02	F10	90	3.54
4"	100	27	1.063	27	1.063	70	2.76	F07	125	4.92	F12	90	3.54
5"	125	36	1.417	36	1.417	102	4.02	F10	140	5.51	F14	130	5.12
6"	150	36	1.417	36	1.417	102	4.02	F10	140	5.51	F14	130	5.12
8"	200	36	1.417	36	1.417	102	4.02	F10	140	5.51	F14	130	5.12
10"	250	46	1.811	46	1.811	165	6.50	F16				145	5.71
12"	300	46	1.811	46	1.811	165	6.50	F16				145	5.71

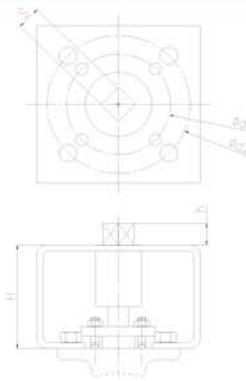

Actuator Mounting Dimensions Are for Reference and Cost Estimating Purposes Only!

Request Certified Drawing From the Factory Prior to Manufacturing Mounting Hardware.

Easy-Link Mounting Hardware Designed for ISO 5211.

This information is designed for Class 150 valves with soft seats. The same mounting may also work for other actuators and pressure classes. Consult factory for additional information.

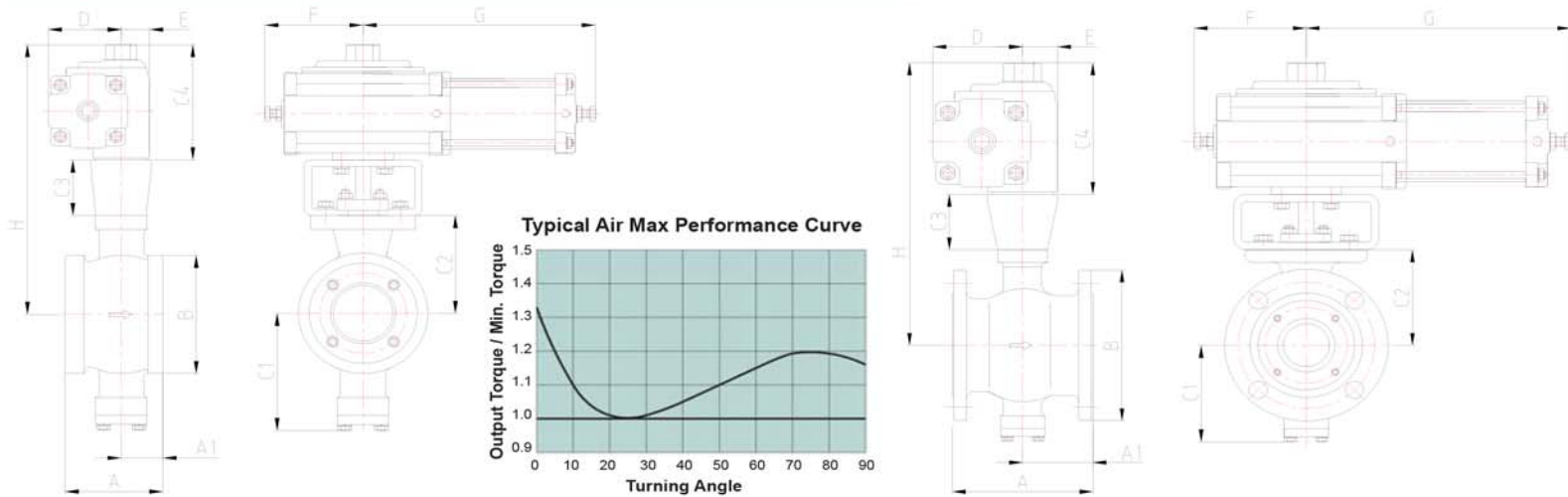

Air-Max Cylinder actuators feature a high opening torque for on-off applications and also maintain a high operating torque throughout the full stroke for modulating service.

Class 150 Wafer Valves **Soft Seated** shown with Air-Max Spring Return pneumatic cylinder actuator

SIZE		Spring Return Actuator Model	A	A1	B	C1	C2	C3	C4	D	E	F	G	H
NPS	DN													
1"	25	ZDQ41-100	2.44	1.06	2.68	3.46	2.95	2.36	5.43	3.54	1.38	5.71	16.73	10.75
1 1/4"	32	ZDQ41-100	2.44	0.87	3.07	3.46	3.15	2.36	5.43	3.54	1.38	5.71	16.73	10.94
1 1/2"	40	ZDQ41-100	2.44	0.87	3.35	3.46	3.35	2.36	5.43	3.54	1.38	5.71	16.73	11.14
2"	50	ZDQ41-100	2.95	1.22	3.94	3.94	3.54	2.36	5.43	3.54	1.38	5.71	16.73	11.34
2 1/2"	65	ZDQ41-125	3.54	1.38	4.72	4.65	4.33	2.36	5.43	3.54	1.38	5.71	16.73	12.13
3"	80	ZDQ50-125	3.94	1.57	5.12	4.76	4.69	2.76	5.83	4.25	1.69	6.30	20.47	13.27
4"	100	ZDQ50-160	4.53	1.77	6.22	5.24	5.16	2.76	5.83	4.25	1.69	6.30	20.47	13.74
5"	125	ZDQ50-160	5.08	2.01	7.24	6.02	5.91	2.76	5.83	4.25	1.69	6.30	20.47	14.49
6"	150	ZDQ60-200	6.30	2.56	8.50	7.09	7.01	3.15	7.20	5.16	1.85	7.09	24.02	17.36
8"	200	ZDQ80-200	7.87	3.23	10.55	7.87	8.07	3.15	9.09	6.65	2.76	9.65	28.15	20.31
10"	250	ZDQ80-250	9.45	3.58	12.68	9.65	9.45	3.94	9.09	6.65	2.76	9.65	28.54	22.48

Class 150 Flanged Valves **Soft Seated** shown with Air-Max Spring Return pneumatic cylinder actuator

SIZE		Spring Return Actuator Model	A	A1	B	C1	C2	C3	C4	D	E	F	G	H
NPS	DN													
1"	25	ZDQ41-100	4.02	2.24	4.25	3.46	3.07	2.36	5.43	3.54	1.38	5.71	16.73	10.87
1 1/4"	32	ZDQ41-100	4.02	2.05	4.62	3.46	3.35	2.36	5.43	3.54	1.38	5.71	16.73	11.14
1 1/2"	40	ZDQ41-100	4.49	2.56	5.00	3.46	3.35	2.36	5.43	3.54	1.38	5.71	16.73	11.14
2"	50	ZDQ41-100	4.88	2.64	6.00	3.46	3.66	2.36	5.43	3.54	1.38	5.71	16.73	11.46
2 1/2"	65	ZDQ41-125	5.71	3.35	7.00	4.65	4.41	2.36	5.43	3.54	1.38	5.71	16.73	12.20
3"	80	ZDQ50-125	6.50	3.64	7.50	4.76	4.69	2.76	5.83	4.25	1.69	6.30	20.47	13.27
4"	100	ZDQ50-160	7.64	4.41	9.00	5.24	5.16	2.76	5.83	4.25	1.69	6.30	20.47	13.74
5"	125	ZDQ50-160	8.39	4.65	10.00	6.02	5.91	2.76	5.83	4.25	1.69	6.30	20.47	14.49
6"	150	ZDQ60-200	9.02	4.88	11.00	7.09	7.01	3.15	7.20	5.16	1.85	7.09	24.02	17.36
8"	200	ZDQ80-200	9.57	4.80	13.50	7.87	8.07	3.15	9.09	6.65	2.76	9.65	28.15	20.31
10"	250	ZDQ80-250	11.69	5.83	16.00	9.65	9.45	3.94	9.09	6.65	2.76	9.65	28.54	22.48
12"	300	ZDQ100-300	13.31	6.30	19.00	10.83	10.59	3.94	10.24	7.72	3.50	11.02	35.43	24.76

Class 300 Flanged Valves **Soft Seated** shown with Air-Max Spring Return pneumatic cylinder actuator

SIZE		Spring Return Actuator Model	A	A1	B	C1	C2	C3	C4	D	E	F	G	H
NPS	DN													
1"	25	ZDQ41-125	4.17	2.24	4.88	3.46	3.19	2.36	5.43	3.54	1.38	5.71	16.73	10.98
1 1/4"	32	ZDQ41-125	4.17	2.05	5.25	3.46	3.46	2.36	5.43	3.54	1.38	5.71	16.73	11.26
1 1/2"	40	ZDQ50-125	4.80	2.72	6.12	3.46	3.35	2.36	5.83	4.25	1.69	6.30	20.47	11.54
2"	50	ZDQ50-160	4.88	2.44	6.50	4.13	3.94	2.36	5.83	4.25	1.69	6.30	20.47	12.13
3"	80	ZDQ60-200	6.50	3.25	8.25	5.35	5.31	2.76	7.20	5.16	1.85	7.09	24.02	15.28
4"	100	ZDQ80-200	7.64	4.02	10.00	5.71	5.59	2.76	9.09	6.65	2.76	9.65	28.15	17.44
6"	150	ZDQ100-300	9.02	4.51	12.50	8.07	7.83	3.94	10.24	7.72	3.50	11.02	35.43	22.01
8"	200	ZDQ130-350	9.57	4.39	15.00	8.86	8.62	3.94	12.32	10.04	3.54	13.39	43.31	24.88
10"	250	ZDQ160-450	11.69	5.31	17.50	11.02	10.94	5.51	14.29	11.38	5.16	16.93	46.06	30.75
12"	300	ZDQ160-500	13.31	5.98	20.50	11.42	11.54	5.51						

Actuator Sizings are for 80 psi supply air and for MC-pulp medium

Certain dimensions such as bracket height may vary, consult factory for confirmation

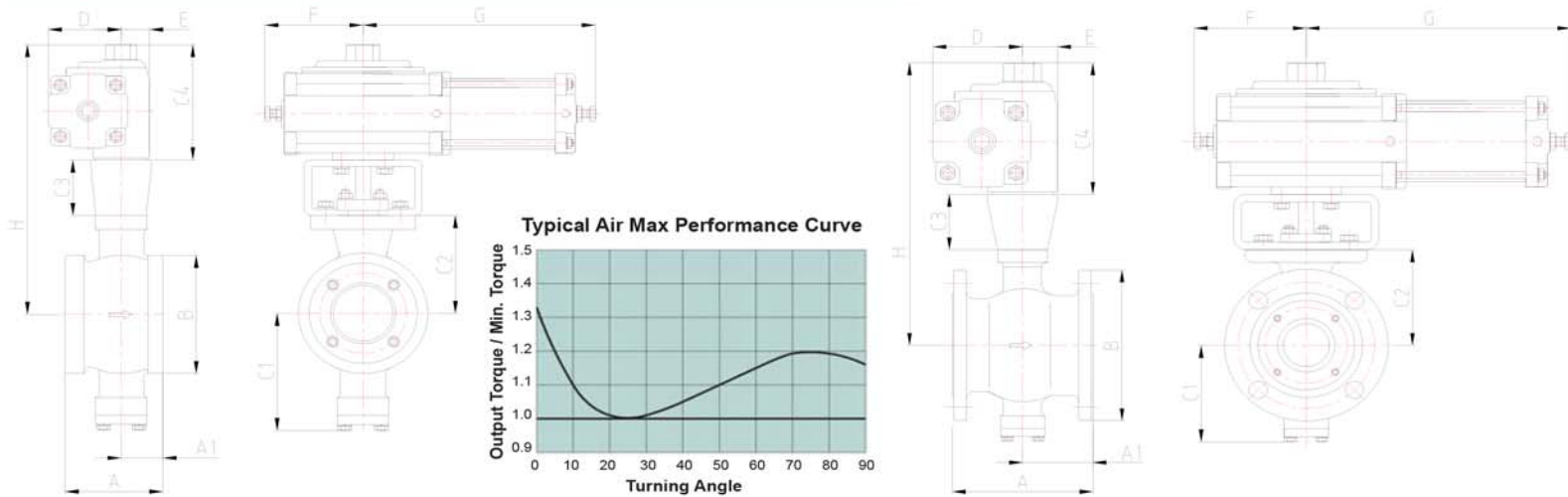

Air-Max Cylinder actuators feature a high opening torque for on-off applications and also maintain a high operating torque throughout the full stroke for modulating service.

Class 150 Wafer Valves **Metal Seated** shown with Air-Max Spring Return pneumatic cylinder actuator

SIZE		Spring Return Actuator Model	A	A1	B	C1	C2	C3	C4	D	E	F	G	H
NPS	DN													
1"	25	ZDQ41-100	2.44	1.06	2.68	3.46	2.95	2.36	5.43	3.54	1.38	5.71	16.73	10.75
1 1/4"	32	ZDQ41-100	2.44	0.87	3.07	3.46	3.15	2.36	5.43	3.54	1.38	5.71	16.73	10.94
1 1/2"	40	ZDQ41-100	2.44	0.87	3.35	3.46	3.35	2.36	5.43	3.54	1.38	5.71	16.73	11.14
2"	50	ZDQ41-100	2.95	1.22	3.94	3.94	3.54	2.36	5.43	3.54	1.38	5.71	16.73	11.34
2 1/2"	65	ZDQ41-125	3.54	1.38	4.72	4.65	4.33	2.36	5.43	3.54	1.38	5.71	16.73	12.13
3"	80	ZDQ50-125	3.94	1.57	5.12	4.76	4.69	2.76	5.83	4.25	1.69	6.30	20.47	13.27
4"	100	ZDQ50-160	4.53	1.77	6.22	5.24	5.16	2.76	5.83	4.25	1.69	6.30	20.47	13.74
5"	125	ZDQ50-160	5.08	2.01	7.24	6.02	5.91	2.76	5.83	4.25	1.69	6.30	20.47	14.49
6"	150	ZDQ60-200	6.30	2.56	8.50	7.09	7.01	3.15	7.20	5.16	1.85	7.09	24.02	17.36
8"	200	ZDQ80-200	7.87	3.23	10.55	7.87	8.07	3.15	9.09	6.65	2.76	9.65	28.15	20.31
10"	250	ZDQ80-250	9.45	3.58	12.68	9.65	9.45	3.94	9.09	6.65	2.76	9.65	28.54	22.48

Class 150 Flanged Valves **Metal Seated** shown with Air-Max Spring Return pneumatic cylinder actuator

SIZE		Spring Return Actuator Model	A	A1	B	C1	C2	C3	C4	D	E	F	G	H
NPS	DN													
1"	25	ZDQ41-100	4.02	2.24	4.25	3.46	3.07	2.36	5.43	3.54	1.38	5.71	16.73	10.87
1 1/4"	32	ZDQ41-100	4.02	2.05	4.62	3.46	3.35	2.36	5.43	3.54	1.38	5.71	16.73	11.14
1 1/2"	40	ZDQ41-100	4.49	2.56	5.00	3.46	3.35	2.36	5.43	3.54	1.38	5.71	16.73	11.14
2"	50	ZDQ41-100	4.88	2.64	6.00	3.46	3.66	2.36	5.43	3.54	1.38	5.71	16.73	11.46
2 1/2"	65	ZDQ41-125	5.71	3.35	7.00	4.65	4.41	2.36	5.43	3.54	1.38	5.71	16.73	12.20
3"	80	ZDQ50-125	6.50	3.64	7.50	4.76	4.69	2.76	5.83	4.25	1.69	6.30	20.47	13.27
4"	100	ZDQ50-160	7.64	4.41	9.00	5.24	5.16	2.76	5.83	4.25	1.69	6.30	20.47	13.74
5"	125	ZDQ50-160	8.39	4.65	10.00	6.02	5.91	2.76	5.83	4.25	1.69	6.30	20.47	14.49
6"	150	ZDQ60-200	9.02	4.88	11.00	7.09	7.01	3.15	7.20	5.16	1.85	7.09	24.02	17.36
8"	200	ZDQ80-200	9.57	4.80	13.50	7.87	8.07	3.15	9.09	6.65	2.76	9.65	28.15	20.31
10"	250	ZDQ80-250	11.69	5.83	16.00	9.65	9.45	3.94	9.09	6.65	2.76	9.65	28.54	22.48
12"	300	ZDQ100-300	13.31	6.30	19.00	10.83	10.59	3.94	10.24	7.72	3.50	11.02	35.43	24.76

Class 300 Flanged Valves **Metal Seated** shown with Air-Max Spring Return pneumatic cylinder actuator

SIZE		Spring Return Actuator Model	A	A1	B	C1	C2	C3	C4	D	E	F	G	H
NPS	DN													
1"	25	ZDQ41-125	4.17	2.24	4.88	3.46	3.19	2.36	5.43	3.54	1.38	5.71	16.73	10.98
1 1/4"	32	ZDQ41-125	4.17	2.05	5.25	3.46	3.46	2.36	5.43	3.54	1.38	5.71	16.73	11.26
1 1/2"	40	ZDQ50-125	4.80	2.72	6.12	3.46	3.35	2.36	5.83	4.25	1.69	6.30	20.47	11.54
2"	50	ZDQ50-160	4.88	2.44	6.50	4.13	3.94	2.36	5.83	4.25	1.69	6.30	20.47	12.13
3"	80	ZDQ60-200	6.50	3.25	8.25	5.35	5.31	2.76	7.20	5.16	1.85	7.09	24.02	15.28
4"	100	ZDQ80-200	7.64	4.02	10.00	5.71	5.59	2.76	9.09	6.65	2.76	9.65	28.15	17.44
6"	150	ZDQ100-300	9.02	4.51	12.50	8.07	7.83	3.94	10.24	7.72	3.50	11.02	35.43	22.01
8"	200	ZDQ130-350	9.57	4.39	15.00	8.86	8.62	3.94	12.32	10.04	3.54	13.39	43.31	24.88
10"	250	ZDQ160-450	11.69	5.31	17.50	11.02	10.94	5.51	14.29	11.38	5.16	16.93	46.06	30.75
12"	300	ZDQ160-500	13.31	5.98	20.50	11.42	11.54	5.51						

Actuator Sizings are for 80 psi supply air and for MC-pulp medium

Certain dimensions such as bracket height may vary, consult factory for confirmation

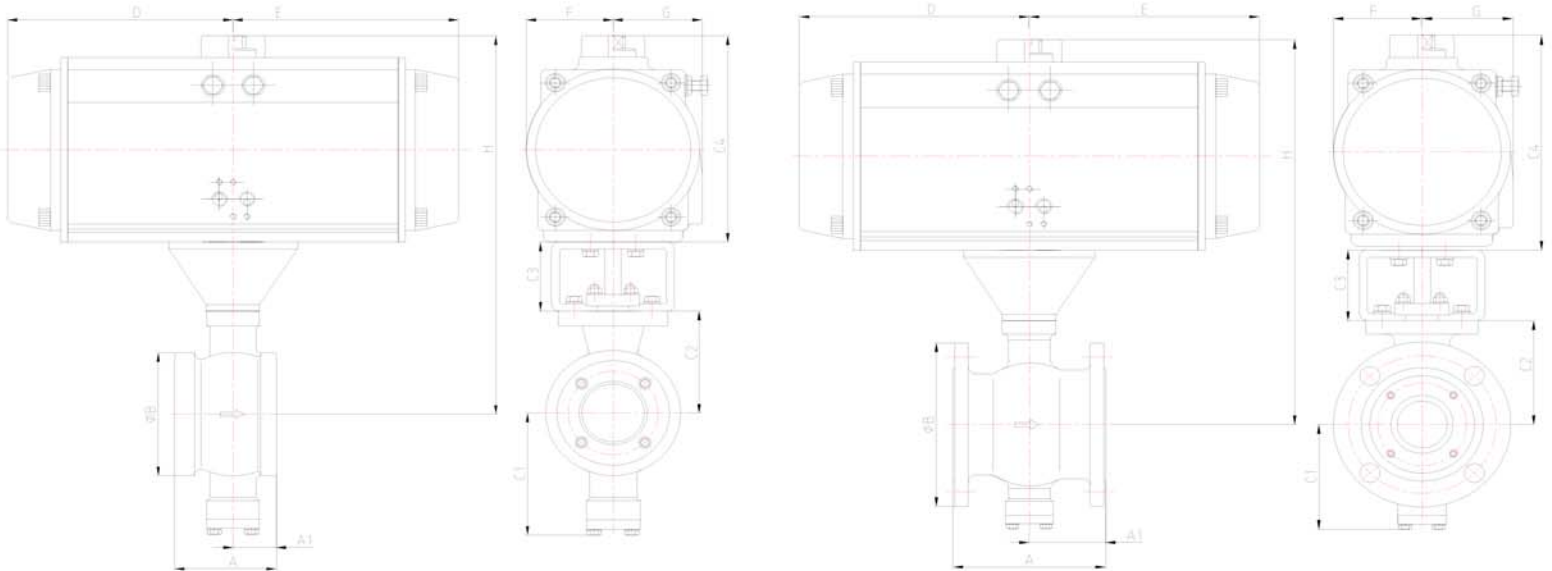

Class 150 Wafer Valves **Soft Seated** shown with Spring Return Rack & Pinion Pneumatic Actuator

SIZE		Spring Return Actuator Model	A	A1	B	C1	C2	C3	C4	D	E	F	G	H
NPS	DN													
1"	25	SR092-10	2.44	1.06	2.68	3.46	2.95	3.54	5.39	5.16	5.16	1.97	2.30	11.88
1 1/4"	32	SR092-10	2.44	0.87	3.07	3.46	3.15	3.54	5.39	5.16	5.16	1.97	2.30	12.08
1 1/2"	40	SR092-10	2.44	0.87	3.35	3.46	3.35	3.54	5.39	5.16	5.16	1.97	2.30	12.28
2"	50	SR092-10	2.95	1.22	3.94	3.94	3.54	3.54	5.39	5.16	5.16	1.97	2.30	12.47
2 1/2"	65	SR092-11	3.54	1.38	4.72	4.65	4.33	3.54	5.39	5.16	5.16	1.97	2.30	13.26
3"	80	SR125-10	3.94	1.57	5.12	4.76	4.69	3.54	6.89	5.83	5.83	2.66	2.93	15.12
4"	100	SR125-10	4.53	1.77	6.22	5.24	5.16	3.54	6.89	5.83	5.83	2.66	2.93	15.59
5"	125	SR160-08	5.08	2.01	7.24	6.02	5.91	5.12	8.54	9.02	9.02	3.43	3.43	19.57
6"	150	SR190-10	6.30	2.56	8.50	7.09	7.01	5.12	10.24	10.40	10.40	4.06	4.06	22.37
8"	200	SR210-10	7.87	3.23	10.55	7.87	8.07	5.12	11.22	11.10	11.10	4.45	4.45	24.41
10"	250	SR270-12	9.45	3.58	12.68	9.65	9.45	5.71	14.01	13.90	13.90	5.79	5.79	29.17

Class 150 Flanged Valves **Soft Seated** shown with Spring Return Rack & Pinion Pneumatic Actuator

SIZE		Spring Return Actuator Model	A	A1	B	C1	C2	C3	C4	D	E	F	G	H
NPS	DN													
1"	25	SR092-10	4.02	2.24	4.25	3.46	3.07	3.54	5.39	5.16	5.16	1.97	2.30	12.00
1 1/4"	32	SR092-10	4.02	2.05	4.62	3.46	3.15	3.54	5.39	5.16	5.16	1.97	2.30	12.08
1 1/2"	40	SR092-10	4.49	2.56	5.00	3.46	3.35	3.54	5.39	5.16	5.16	1.97	2.30	12.28
2"	50	SR092-10	4.88	2.64	6.00	3.94	3.66	3.54	5.39	5.16	5.16	1.97	2.30	12.59
2 1/2"	65	SR092-11	5.71	3.35	7.00	4.65	4.41	3.54	5.39	5.16	5.16	1.97	2.30	13.34
3"	80	SR125-10	6.50	3.64	7.50	4.76	4.69	3.54	6.89	5.83	5.83	2.66	2.93	15.12
4"	100	SR125-10	7.64	4.41	9.00	5.24	5.16	3.54	6.89	5.83	5.83	2.66	2.93	15.59
5"	125	SR160-08	8.39	4.65	10.00	6.02	5.91	5.12	8.54	9.02	9.02	3.43	3.43	19.57
6"	150	SR190-10	9.02	4.88	11.00	7.09	7.01	5.12	10.24	10.40	10.40	4.06	4.06	22.37
8"	200	SR210-10	9.57	4.80	13.50	7.87	8.07	5.12	11.22	11.10	11.10	4.45	4.45	24.41
10"	250	SR270-12	11.69	5.83	16.00	9.65	9.45	5.71	14.01	13.90	13.90	5.79	5.79	29.17
12"	300	SR300-12	13.31	6.30	19.00	11.42	10.59	5.71	14.90	14.60	14.60	6.40	6.40	31.20

Class 300 Flanged Valves **Soft Seated** shown with Spring Return Rack & Pinion Pneumatic Actuator

SIZE		Spring Return Actuator Model	A	A1	B	C1	C2	C3	C4	D	E	F	G	H
NPS	DN													
1"	25	SR092-10	4.17	2.24	4.88	3.46	3.19	3.54	5.39	5.16	5.16	1.97	2.30	12.12
1 1/2"	40	SR105-09	4.80	2.72	6.12	3.46	3.35	3.54	6.02	5.28	5.28	2.26	2.52	12.91
2"	50	SR105-10	4.88	2.44	6.50	4.13	3.94	3.54	6.02	5.28	5.28	2.26	2.52	13.50
3"	80	SR140-10	6.50	3.25	8.25	5.35	5.31	4.72	7.54	7.68	7.68	2.95	3.03	17.57
4"	100	SR160-09	7.64	4.02	10.00	5.71	5.59	4.72	8.54	9.02	9.02	3.43	3.43	18.85
6"	150	SR240-09	9.02	4.51	12.50	8.07	7.83	5.71	12.56	11.85	11.85	5.12	5.12	26.10
8"	200	SR270-12	9.57	4.39	15.00	8.66	8.62	5.71	14.01	13.90	13.90	5.79	5.79	28.34
10"	250	SRB-350-10	11.69	5.31	17.50	10.55	10.94	7.28	17.00	16.95	16.95	7.50	7.50	35.22
12"	300	SRB400-11	13.31	5.98	20.50	11.42	11.54	7.28	19.40	18.20	18.20	10.15	10.15	38.22

Actuator Sizings are for 80 psi supply air and for MC-pulp medium

Certain dimensions such as bracket height may vary, consult factory for confirmation

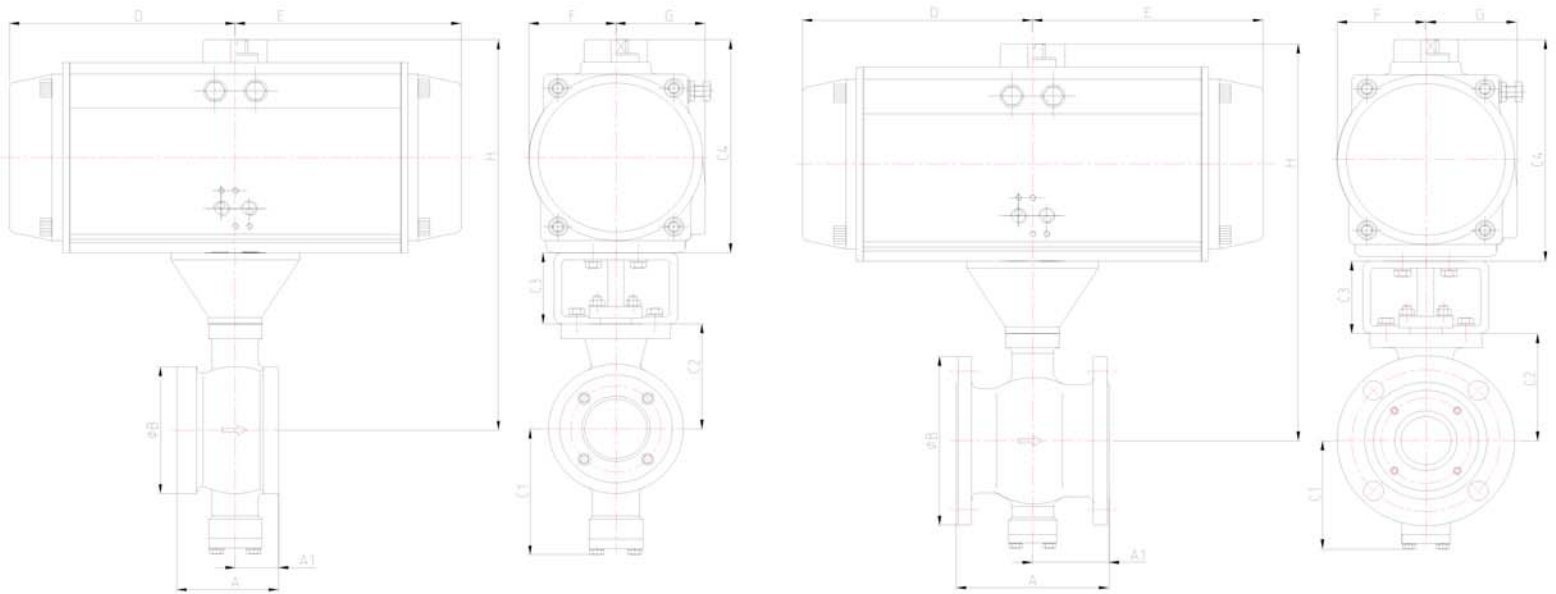

Class 150 Wafer Valves **Metal Seated** shown with Spring Return Rack & Pinion Pneumatic Actuator

SIZE		Spring Return Actuator Model	A	A1	B	C1	C2	C3	C4	D	E	F	G	H
NPS	DN													
1"	25	SR092-12	2.44	1.06	2.68	3.46	2.95	3.54	5.39	5.16	5.16	1.97	2.30	11.88
1 1/2"	40	SR092-10	2.44	0.87	3.35	3.46	3.35	3.54	5.39	5.16	5.16	1.97	2.30	12.28
2"	50	SR105-12	2.95	1.22	3.94	3.94	3.54	3.54	6.02	5.28	5.28	2.26	2.52	13.10
2 1/2"	65	SR125-12	3.54	1.38	4.72	4.65	4.33	3.54	6.89	5.83	5.83	2.66	2.93	14.76
3"	80	SR125-12	3.94	1.57	5.12	4.76	4.69	3.54	6.89	5.83	5.83	2.66	2.93	15.12
4"	100	SR140-12	4.53	1.77	6.22	5.24	5.16	3.54	7.54	7.68	7.68	2.95	3.03	16.24
5"	125	SR160-10	5.08	2.01	7.24	6.02	5.91	5.12	8.54	9.02	9.02	3.43	3.43	19.57
6"	150	SR190-10	6.30	2.56	8.50	7.09	7.01	5.12	10.24	10.40	10.40	4.06	4.06	22.37
8"	200	SR210-10	7.87	3.23	10.55	7.87	8.07	5.12	11.22	11.10	11.10	4.45	4.45	24.41
10"	250	SR270-10	9.45	3.58	12.68	9.65	9.45	5.71	14.01	13.90	13.90	5.79	5.79	29.17

Class 150 Flanged Valves **Metal Seated** shown with Spring Return Rack & Pinion Pneumatic Actuator

SIZE		Spring Return Actuator Model	A	A1	B	C1	C2	C3	C4	D	E	F	G	H
NPS	DN													
1"	25	SR092-12	4.02	2.24	4.25	3.46	3.07	3.54	5.39	5.16	5.16	1.97	2.30	12.00
1 1/2"	40	SR092-10	4.49	2.56	5.00	3.46	3.35	3.54	5.39	5.16	5.16	1.97	2.30	12.28
2"	50	SR105-12	4.88	2.64	6.00	3.94	3.66	3.54	6.02	5.28	5.28	2.26	2.52	13.22
2 1/2"	65	SR125-12	5.71	3.35	7.00	4.65	4.41	3.54	6.89	5.83	5.83	2.66	2.93	14.84
3"	80	SR125-12	6.50	3.64	7.50	4.76	4.69	3.54	6.89	5.83	5.83	2.66	2.93	15.12
4"	100	SR140-12	7.64	4.41	9.00	5.24	5.16	3.54	7.54	7.68	7.68	2.95	3.03	16.24
5"	125	SR160-10	8.39	4.65	10.00	6.02	5.91	5.12	8.54	9.02	9.02	3.43	3.43	19.57
6"	150	SR190-10	9.02	4.88	11.00	7.09	7.01	5.12	10.24	10.40	10.40	4.06	4.06	22.37
8"	200	SR210-10	9.57	4.80	13.50	7.87	8.07	5.12	11.22	11.10	11.10	4.45	4.45	24.41
10"	250	SR270-10	11.69	5.83	16.00	9.65	9.45	5.71	14.01	13.90	13.90	5.79	5.79	29.17
12"	300	SRB350-09	13.31	6.30	19.00	11.42	10.59	5.71	17.00	16.95	16.95	7.50	7.50	33.30

Class 300 Flanged Valves **Metal Seated** shown with Spring Return Rack & Pinion Pneumatic Actuator

SIZE		Spring Return Actuator Model	A	A1	B	C1	C2	C3	C4	D	E	F	G	H
NPS	DN													
1"	25	SR105-10	4.17	2.24	4.92	3.46	3.19	3.54	6.02	5.28	5.28	2.26	2.52	12.75
1 1/2"	40	SR125-09	4.80	2.72	6.10	3.46	3.35	3.54	6.89	5.83	5.83	2.66	2.93	13.78
2"	50	SR125-09	4.88	2.44	6.50	4.13	3.94	3.54	8.54	9.02	9.02	3.43	3.43	16.02
3"	80	SR160-10	6.50	3.25	8.27	5.35	5.31	4.72	8.54	9.02	9.02	3.43	3.43	18.57
4"	100	SR190-09	7.64	4.02	10.04	5.71	5.59	4.72	10.24	10.40	10.40	4.06	4.06	20.55
6"	150	SR270-10	9.02	4.51	12.60	8.07	7.83	5.71	14.01	13.90	13.90	5.79	5.79	27.55
8"	200	SRB350-09	9.57	4.39	14.96	8.66	8.62	5.71	14.01	13.90	13.90	5.79	5.79	28.34

Actuator Sizings are for 80 psi supply air and for MC-pulp medium

Certain dimensions such as bracket height may vary, consult factory for confirmation

Size	RV	F1	-	01	SS	51	S7	B	56	R	V	N	
1	2	3		4	5	6	7	8	9	10	11	12	*
Size	RV	F1	-	03	CS	51	S7	B	56	R	V	N	
1	2	3		4	5	6	7	8	9	10	11	12	*
Size	RV	F1	-	01	SS	50	S7	A	DO	R	V	N	
1	2	3		4	5	6	7	8	9	10	11	12	*

Model Numbers
Are Shown For
the More Standard
Inventory Valves

1. Valve Sizes

025	1"	DN25	080	3"	DN80	300	12"	DN300	550	22"	DN550
032	1 1/4"	DN32	100	4"	DN100	350	14"	DN350	600	24"	DN600
040	1 1/2"	DN40	150	6"	DN150	400	16"	DN400	650	26"	DN650
050	2"	DN50	200	8"	DN200	450	18"	DN450	700	28"	DN700
065	2 1/2"	DN65	250	10"	DN250	500	20"	DN500	750	30"	DN750

2. Valve Series

RV	Segment Ball Valve	* * *
----	--------------------	-------

3. Connection Type

F1	Flanged, Raised Face	* * *
D1	Wafer, Raised Face	

4. Pressure Rating

01	150 #	* *
03	300 #	*
06	600 #	

5. Body Material

CS	WCB / Carbon Steel	*
S4	CF8 / SS304	
S3	CF3 / SS304L	
SS	CF8M / SS316	* *
SL	CF3M / SS316L	
S1	CG8M / SS317	
LC	LCB / Low Temp Carbon Steel	
C6	WC6 / Alloy Steel	
DP	Duplex 2205	

6. Ball Material and Treatment

Select both material and treatment

Ball Material	Surface Treatment	
3	CF8	0 No Treatment *
4	CF3	1 Hard Chrome * *
5	CF8M * * *	3 Nickle Based Alloy
6	CF3M	4 Tungsten Carbide
7	CG8M	5 Nitriding
8	Duplex SS	6 Stellite

7. Stem Material

S4	CF8 / SS304	
S3	CF3 / SS304L	
SS	CF8M / SS316	
SL	CF3M / SS316L	
S1	CG8M / SS317	
S7	17-4Ph	* * *
DP	Duplex 2205	

8. Seat Style Selection

A	Soft Seat	
B	Standard Metal Seat	* *
C	High Temp Metal Seat	*

9. Seat Material Selection

Metal Seat Material & Treatment

Select both material and treatment, metal seat only

Seat Material	Surface Treatment		
3	304	1	Hard Chrome
4	304L	2	Chrome Carbide
5	316 * *	3	Nickle Based Alloy
6	316L	4	Tungsten Carbide
7	317	5	Nitriding
8	Duplex 2205	6	Stellite * *

Soft Seat Material

Soft seat only

Seat Material	
TO	PTFE
FO	TFM
NO	Nylon
RO	RPTFE
PO	PEEK
DO	DEVLON *
Others	S/F

10. Packing Material

T	PTFE	
R	RIFE	* * *
F	TFM	
G	Graphite	

11. O-Ring Material

E	EPDM, -20 ~ 248 °F (-29 ~ 120 °C)	
V	VITON, -20 ~ 356 °F (-29 ~ 180 °C)	* * *
A	PFA, -20 ~ 446 °F (-29 ~ 230 °C)	
F	FEP, -20 ~ 320 °F (-29 ~ 160 °C)	
G	Graphite, -20 ~ 797 °F (-29 ~ 425 °C)	

12. Operator

L	Locking Lever	
P	10 Position Handle	
G	Gear Operator	
A	Actuator	
N	Bare Stem	* * *

Stayflow's Sentinel Series
Special Alloy Options - Consult Factory

