



DRIBBLE CONTROL SYSTEM

Weather Proof Design - DC4
Explosion Proof Design - DC7

Stayflow's Dribble Control Systems effectively converts a ball valve into a two stage shutoff valve for the exact measurement and filling of ingredients required in batch processing

Stayflow's DC two stage system is a complete unit consisting of one (1) limit switch, (1) 3-way solenoid valve, (1) 2-way (normally open) solenoid valve and a fail safe actuator, factory assembled and tested.



FEATURES:

- Reduces the flow rate at a given point during a filling operation, giving you the ability to more accurately and efficiently fill a vessel.
- Assemblies are available in NEMA 4 & 4X (DC4) and NEMA 4, 4X, 7 & 9 (DC7)
- **Flow dampening.** With the two stage package, valves can be partially closed and then completely closed gradually. This dramatically reduces shock (water hammer) to piping system and valves.
- Occupies minimal space and eliminates costly bypass piping assembly.

ORDERING INFORMATION - packages for spring return actuators

Nema Rating	Package Model no.	3-way Solenoid (ASCO®)	2-way Solenoid (ASCO®)	Solenoid Voltage	Solenoid Body Material
4, 4X, 7 & 9	DCS-AMYB-11B1	EF8320G184	EF8262G93	120VAC-60Hz	Brass
4 & 4X	DCS-AMYB-11B1	8320G184	8262G93	120VAC-60Hz	Brass

Stayflow's DC system is an ideal device for filling or metering vessels and flow dampening

OPERATION / INSTALLATION

Two voltage sources to power both solenoid valves (#1 and #2). Contact logic may be provided by flow meters, scales, level sensors.

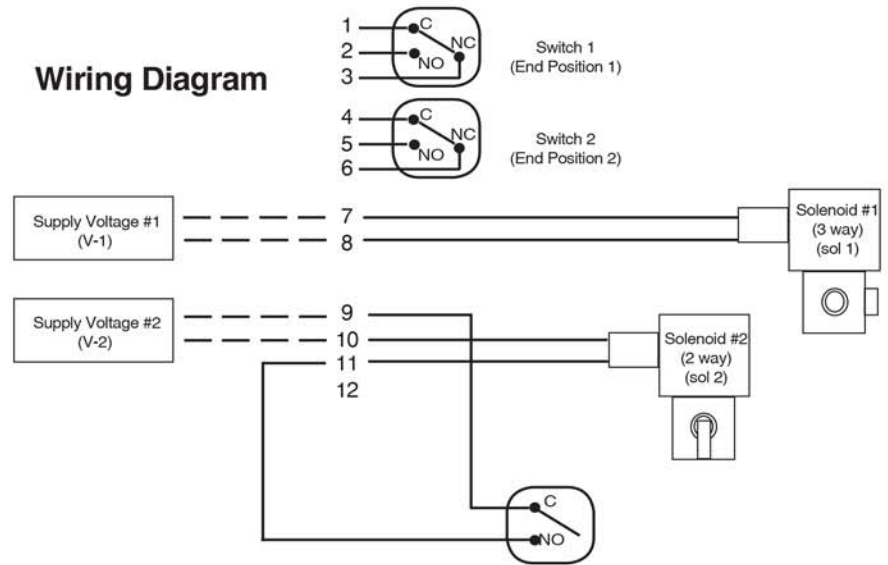

Installation Procedure / Sequence of Operation

! Be sure voltage and air pressure supplied match solenoid specifications.

1. Connect power and clean filtered air to proper positions. Ensure that all air connections are tight and all electrical connections are secured at their proper terminal points.
2. With no power to V-1 and V-2, the valve should be in the fully closed position (sequence #1)
3. Energize V-1 and V-2, solenoid #1 will energize allowing the air pressure to rotate the valve/actuator package to the fully open position.
4. De-energize V-1 and the package will rotate in the opposite direction until the white cam trips switch 3 (blue) and energizes solenoid #2. This will stop the valve rotation at the set mid position. If the mid position is incorrect, estimate approximately how many degrees of rotation the cam needs to be adjusted. **CAUTION** - do not adjust cam until the unit is in the fully closed position as the unit might rotate unexpectedly if the cam is adjusted under power.
5. Finally, de-energize V-2 (both V-1 and V-2 will be de-energized) and solenoid #2 will be de-energized and the valve/actuator package will rotate to the fully closed position. One full cycle has just been completed. If the mid set position requires adjustment, adjust the package now
6. Repeat steps 4-6 to verify adjustment and/or re-adjust dribble position.

! Do not adjust cams while cycling system as the unit might shift unexpectedly

Stage No.	Flow Condition Required	Supply Volt. 1 (V-1)	Supply Volt. 2 (V-2)	Solenoid #1 (Sol 1)	Solenoid #2 (Sol 2)
1	Shut off	De-energize	De-energize	De-energize	De-energize
2	Full Flow	Energize	Energize	Energize	De-energize
3	Reduced Flow	De-energize	Energize	De-energize	Energize
4	Shut off	De-energize	De-energize	De-energize	De-energize