



**VBFLY-CLH-CWH**

# High Performance Butterfly Valves

Available with Soft Seating, Metal Seating & Fire Safe Design



**Size Range**  
**2" thru 24", optional thru 120"**  
**ANSI Class 150/300/600/900**



# High Performance Double Offset Butterfly Valve

Type : Wafer, Lug, Flanged

Size : 2" ~ 48"  
DN50~DN1200

Pressure Rating : Class 150, Class 300, JIS10K, JIS16K  
PN10, PN16, PN20, PN25, PN40, PN64,

Temperature Rating : -27°F ~ 1112°F  
-29°C ~ 600°C

Patented Floating Seat Retainer

Bi-directional Zero Leakage

Low Fugitive Emission System

Fire Safe : Compliance with API 607

High Cycle Life

users in a wide range of applications in many industries including:

- |                             |                            |                                       |
|-----------------------------|----------------------------|---------------------------------------|
| 1. Chemical & petrochemical | 5. Food industries         | 9. Steel & iron industries            |
| 2. Power generation plants  | 6. LNG, HRSG industries    | 10. Pulp & paper plants               |
| 3. Ship building industries | 7. Oil refinery industries | 11. Coal & mining industries          |
| 4. Fiber industries         | 8. Desalination industries | 12. Higher Pressure HVAC Applications |

## HIGH PERFORMANCE BUTTERFLY VALVE MODEL NUMBER CODES

Model	Pressure Class		Body Material		Disc Material		Stem Material		Seat Material		Stem Seal		Operator	
Wafer-BW LUG-BL	150	631	316SS	SS	316SS	SS	316SS	SS	RPTFE	R	PTFE	T	Lever	L
	300	731	WCB	CS	Duplex	DP	304SS	S4	PTFE	T	Graphite	G	Gear	G
	600	830	Duplex	DP	Alloy 20	A2	17-4PH	S7	Metal	M			Bare Stem	N
							Duplex	DP	Fire Safe	F			Actuator	A

## ORDERING EXAMPLE BY PART NUMBER

Wafer	Class 150	316SS	316SS	17-4ph	RPTFE	Graphite	Lever
Model	Pressure Class	Body	Disc	Stem	Seat	Stem Seal	Operator
BW	631	SS	SS	S7	R	G	L

For Complete bill of materials see page 6

## DESIGN SPECIFICATIONS

### STANDARDS OF COMPLIANCE

- Body Style : 631/731 wafer and Lug models
- Rating : ANSI Class 150/300
- Applicable Flange Standard : ANSI B16.5
- Valve Design : ASME B16.34, MSS SP-68
- Anti-Blowout : API 609
- Face to Face : API 609, MSS-SP-68, ISO 5752
- Low Fugitive Emission
- Gland Packing System : MSS-SP-143, DIN 3780
- Fire Safe : API 607-6th
- Testing : API 598, ISO 5708, MSS-SP- 258, API 60913
- Leakage : Soft Seat class, Bubble Tight
- ISO Mounting : ISO 5211
- Pressure-Temperature Rating : API 609 & ASME B16.34
- Suitable Flanges
- ANSI: 150, 300 DIN: PN10, 16, 20, 25, 40, & 50
- JIS: 10K, 16K, 20K, 30K, & 40K
- Valve Materials: MEET NACE MR0175

### COMPANY PROFILE

The Tri-Max is a heavy industrial, precisely operating valve. It was founded by Max-Seal and one of our Taiwanese partners with over 40 years of industrial experience and holds TUV, LR, SGS certificates and patents that were issued by authorities such as ISO 9001, CE Mark, API, APU, PED-H.

As a manufacturer, we specialize in manufacturing High Performance Double-Offset Butterfly Valves, Triple-Offset Metal Seated Butterfly Valves, high temperature valves, cryogenic valves, large control valves, field application consulting, ensuring a long life cycle for our valves.

Our team members are experts in the field of chemistry, petrochemical, pulp and paper, thermal power plants, air separation equipment, water treatment, LNG, nuclear powers, and aerospace industry. We have supplied the Tri-Max to Linde AE, US exotic oil Natural Gas (GE Oil & Gas), Brazil Braskem, Taiwan EVA AIR, China Steel, Dairen Chemical Corporation and other international companies.

Max-Seal's core valves are to deliver value to customers by providing high quality valves. By using PTC Creo Parametric CAD, advanced large scale CNC machines, a stable electronic quality control system. We are able to deliver a product with excellent performance, low torque, low sound levels, and a 2 million times ultra-high-cycle butterfly valve. Max-Seal is confident that we are one of the best butterfly valve manufacturers in the world.

## Certifications

	Fugitive Emission:TUV ISO 15848-1	
	ISO 9001:2008	
	CE/PED Module H 2014/68/EU	
	CE/PED Module H 2014/68/EU	
	Fire Safe - ISO 10497:2010	
	Fire Safe - API 607:2010	
	Anti-Loose Lever Operator Ring Certificate Of Patent	
	Reliable Gear Operator Certificate Of Patent	
	Screwless Valve Retainer Ring Certificate Of Patent	

### Low Fugitive Emission Gland Packing System

Compliant with latest DIN 3780 and MSS SP-143

#### Gland Flange and Gland Bushing

A fully adjustable two-piece gland with spherical mating surfaces.

ISO-5211 Mounting

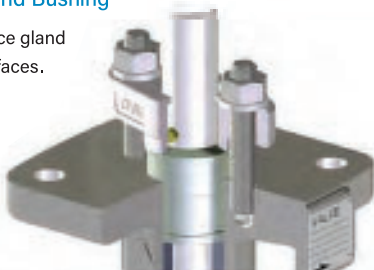

Size Range:  
2" - 44"  
ANSI Class:  
150/300



Exotic Alloy Materials Available  
Consult Factory.

#### Long Gland Bush for Positioning

This long gland bush ensures the gland flange is always kept in the center while adjusting packing gland.

Preventing the gland bush from rubbing and jamming with stem.



# VALVE DESIGN FEATURES



**Standard Seat: RPTFE**  
**Standard Steam Packing: PTFE**

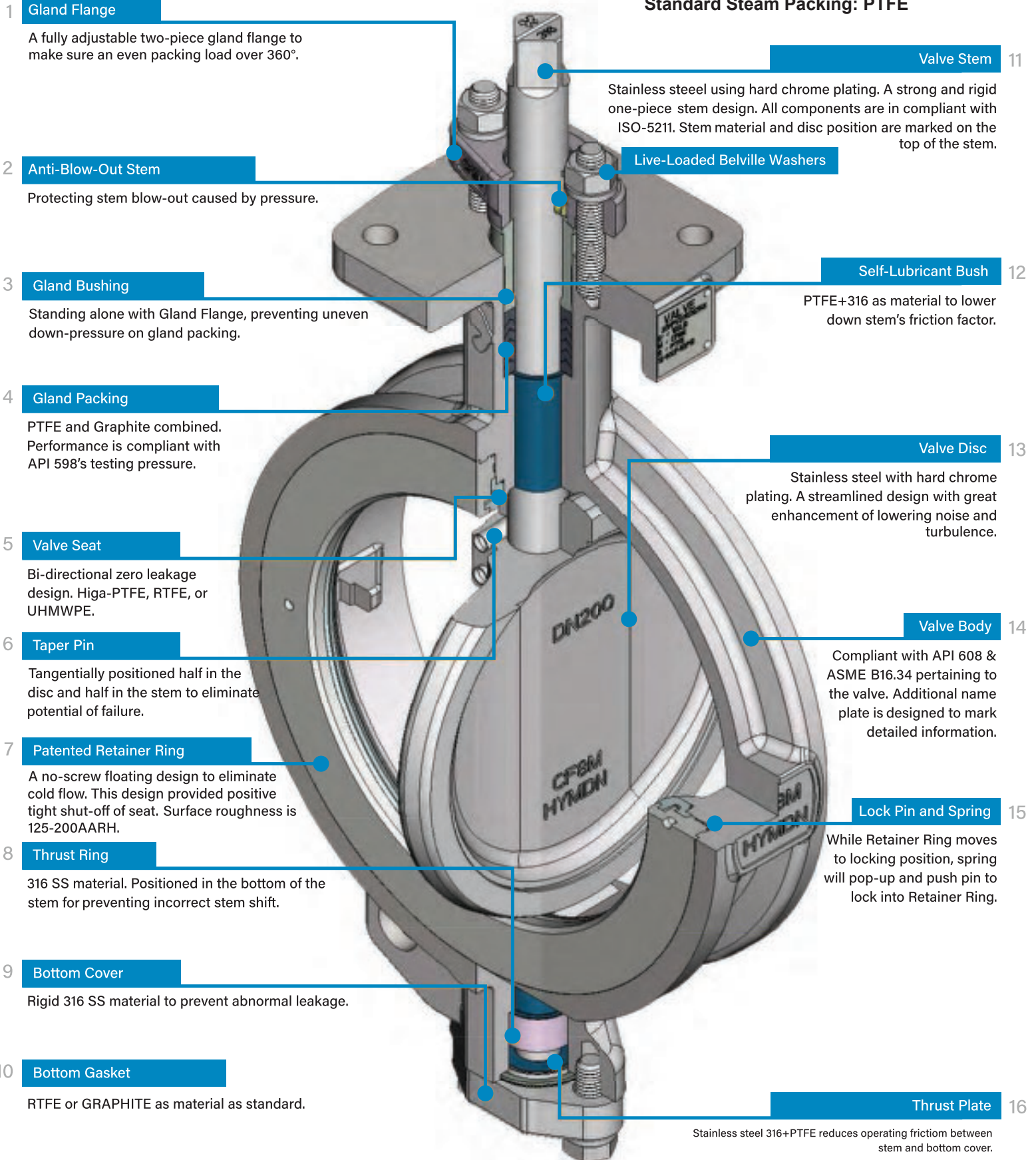

**1 Gland Flange**  
 A fully adjustable two-piece gland flange to make sure an even packing load over 360°.

**2 Anti-Blow-Out Stem**  
 Protecting stem blow-out caused by pressure.

**3 Gland Bushing**  
 Standing alone with Gland Flange, preventing uneven down-pressure on gland packing.

**4 Gland Packing**  
 PTFE and Graphite combined. Performance is compliant with API 598's testing pressure.

**5 Valve Seat**  
 Bi-directional zero leakage design. Higa-PTFE, RTFE, or UHMWPE.

**6 Taper Pin**  
 Tangentially positioned half in the disc and half in the stem to eliminate potential of failure.

**7 Patented Retainer Ring**  
 A no-screw floating design to eliminate cold flow. This design provided positive tight shut-off of seat. Surface roughness is 125-200AARH.

**8 Thrust Ring**  
 316 SS material. Positioned in the bottom of the stem for preventing incorrect stem shift.

**9 Bottom Cover**  
 Rigid 316 SS material to prevent abnormal leakage.

**10 Bottom Gasket**  
 RTFE or GRAPHITE as material as standard.

**11 Valve Stem**  
 Stainless steel using hard chrome plating. A strong and rigid one-piece stem design. All components are in compliant with ISO-5211. Stem material and disc position are marked on the top of the stem.

**Live-Loaded Belleville Washers**

**12 Self-Lubricant Bush**  
 PTFE+316 as material to lower down stem's friction factor.

**13 Valve Disc**  
 Stainless steel with hard chrome plating. A streamlined design with great enhancement of lowering noise and turbulence.

**14 Valve Body**  
 Compliant with API 608 & ASME B16.34 pertaining to the valve. Additional name plate is designed to mark detailed information.

**15 Lock Pin and Spring**  
 While Retainer Ring moves to locking position, spring will pop-up and push pin to lock into Retainer Ring.

**16 Thrust Plate**  
 Stainless steel 316+PTFE reduces operating friction between stem and bottom cover.

# UNIQUE DESIGN FEATURES

## Valve Body

Max-Seal's HP Valves are designed 100% compliant with API 609 and ASME B16.34. Utilizing PTC Creo Parametric (Pro/E) Computer-aided-design in every component and results in the reliability.

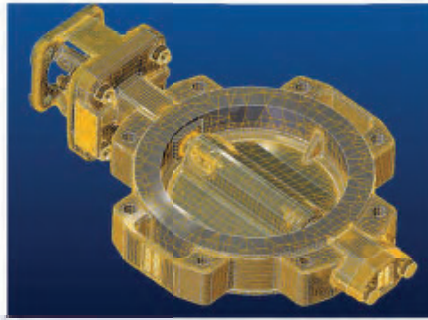

## Top Mounting

Compliant with ISO 5211, York designed with draining system for outdoor service.

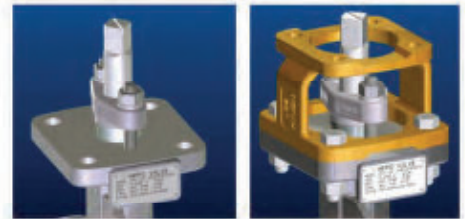

## Anti-Blow-Out Stem and Anti-Electrostatic System

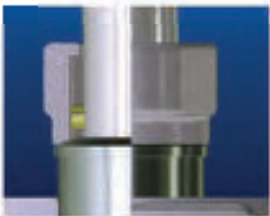

An anti-blow-out design and anti-electrostatic sPste as standard are **compliant with** API 609 and ATEX.



## Name Plate Marking

Max-Seal's tagging system is compliant with MSS-SP-25 & API 609.

## Valve Disc

The valve disc uses stainless steel with computer-aided PTC Creo Parametric software to analyze stress performance to achieve API 598. Based on advance 3D CAD simulation. Max-Seal developed a streamlined disc with lower noise and turbulence. Meanwhile, all our disc and stem surfaces are hard chrome plated. This feature significantly enlarges disc performance of anti-rubbing and anti-shocking which results in better life cycle.

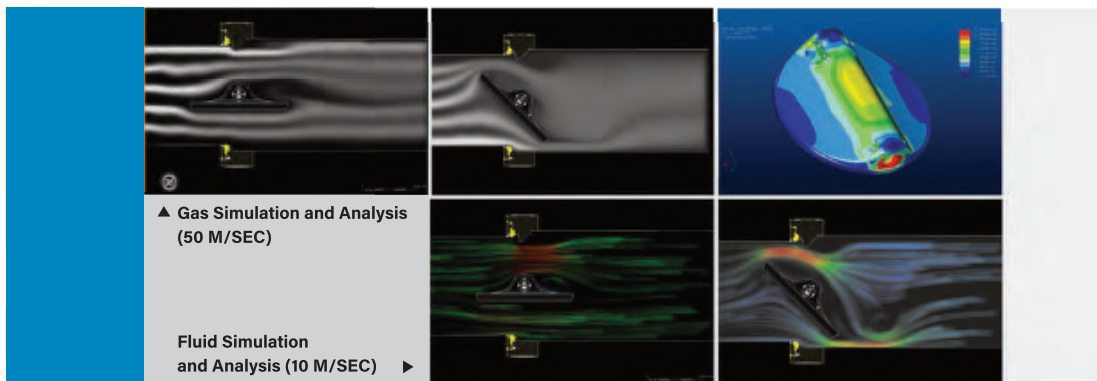

## Patented Retainer Ring

During installation, screwing this ring into internal tooth of the valve body, then a stainless-steel spring catches and the PTFE pin will pop-up to fix retainer ring and valve body in the correct position. This design enlarges the flange-gasket's contact surface, which reduces installation errors.

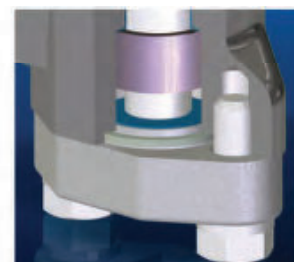

## Thrust Ring for Positioning

A Rigid Thrust Ring keeps stem always in an accurate position.

# Exploded View

ITEM	NAME	MATERIAL		
1	Body	A216 Gr. WCB	A351 Gr. CF8	A351 Gr. CF8M
2	Disc	A351 Gr. CF8		A351 Gr. CF8M
3	Seat	PTFE / MPTFE / RTFE / Metal Seat (Inconel)		
4	Stem	A182 Gr. F6A	A1 . F304	A182 Gr. F316
5	Taper Pin	A182 Gr. F316L		
6	Retainer Ring	A351 Gr. CF8		A3 . CF8M
7	Stem Bushing	B-Woven Fabric Metal		
8	Gland Packing	PTFE/Graphite		TFE
9	Thrust Ring	A351 Gr. CF8M		
10	Thrust Plate	B-Woven Fabric Metal		
11	Gasket	PTFE	TFE	GRA TE
12	Gland Bushing	A351 Gr. CF8M		
13	Anti-Blow-Out Pin	A182 Gr. F316		
14	Gland Flange	A216 Gr. WCB		A351-CF8
15	Bottom Cover	A216 Gr. WCB	A351 Gr. CF8	A351 Gr. CF8M
16	BOLT	304 SS		
17	WASHER	A240 Gr. 304		
18	NUT	304 SS		
19	STUD	304 SS		
20	BELLEVILLE SPRINGS	A240 Gr. 304		

Consult Factory for Options

**Other Seat Options: PEEK, UHMWPE ,S-TEK**

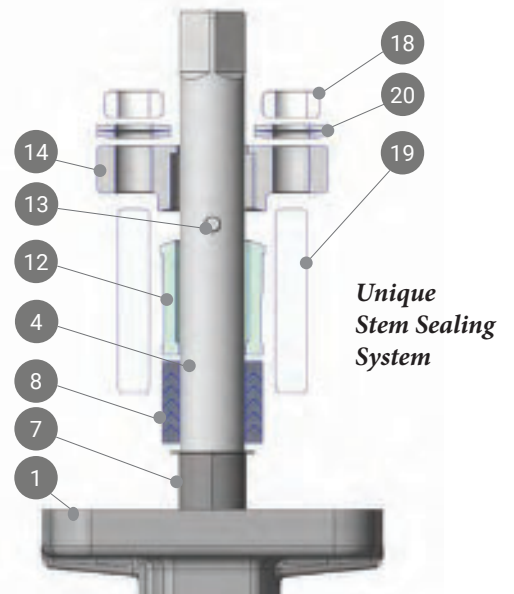
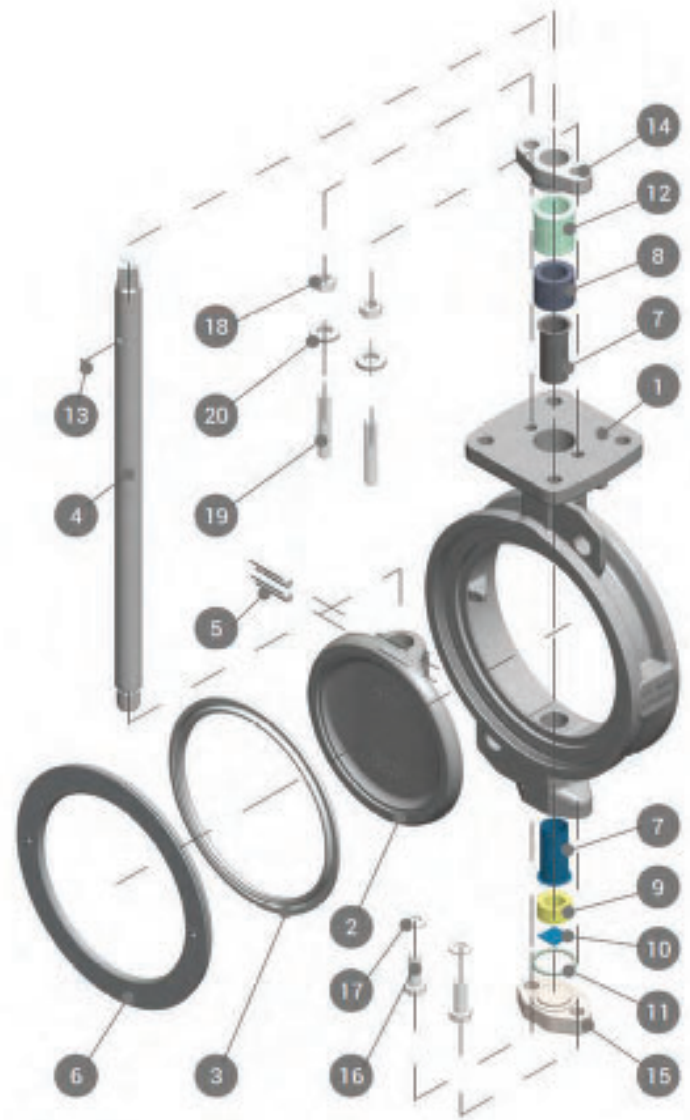

# State of the Art Designs

## Self-Lubricant Bushing

Uses RTFE+S.S 316 stem bushing. Has excellent working temperature, strength rating, and low friction factor. Maintains good seat sealing capability even after high-cycle operations.

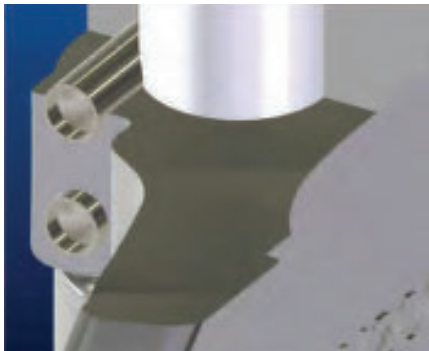
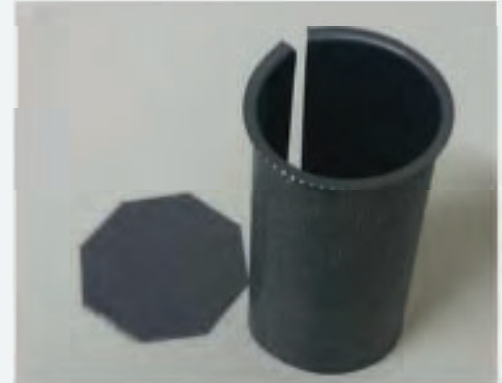

## Taper Pin

Disc taper pins are tangentially positioned in the disc and half in the stem, placing them in compression rather than shear, which eliminates potential of failure. This method is 3 times stronger than traditional shear way.

## Valve Seat

several types of seats such as: Soft Seat, Fire-Safe and Metal Seat. Pressure-Temperature Rating is compliant with API 609 using reliable section and corresponding floating seat to achieve bi-directional, drop-tight zero leakage closure throughout all pressure ranges, as well as full rated differential pressure. This design reduces rubbing and friction between disc and seat which significantly results in longer life cycle. With Higa-PTFE, this Series can keep 285 PSI bi-directional zero leakage after 100,000 times of operations and it will even go higher while valve is working in a vacuum environment.

Comparing to general PTFE, Higa-PTFE has a 2.5 times higher Load-Deformation-Rate 1.5-4 times higher in Acid Alkaline Permeability. PTFE, RTFE, UHMWPE are available as well.



< Standard Type >



< Fire-Safe Type >

# DIMENSIONAL DATA - 1

## Lug Style

BL 631

BL731

## Wafer Style

BW631

BW731

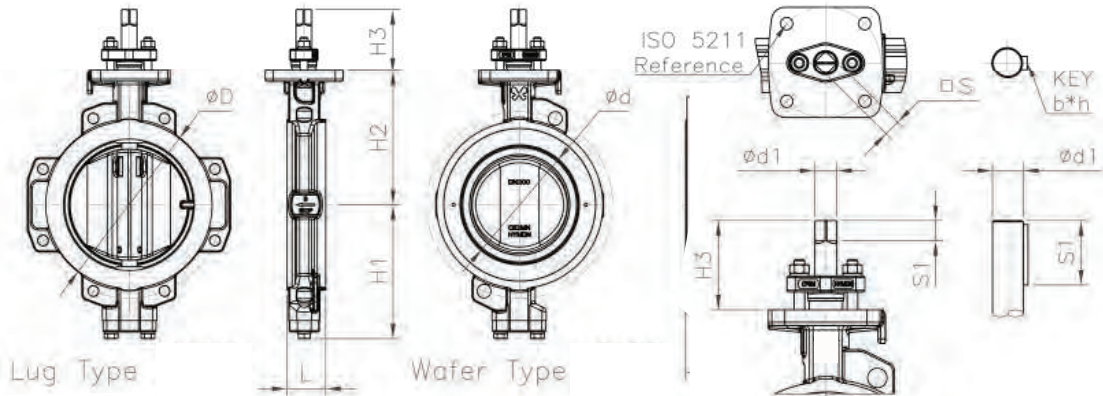

## 150LB

SIZE		L	L1	D	D1	d	H1	H2	H3	S1	d1	S	ISO	Weight (lbs)		
in	mm													Wafer	Lug	Flange
2	50	45	-	95	150	46	118	128	86	18	18	14	F10	13	15	-
2.5	65	48	-	112	180	61	126	136	86	18	18	14	F10	15	17	-
3	80	48	114	126	190	76	134	140	86	18	18	14	F10	17	18	39
4	100	54	127	155	230	96	144	150	86	18	18	14	F10	20	27	41
5	125	57	-	184	255	118	178	170	89	21	22	17	F10	25	39	-
6	150	57	140	215	280	143	190	185	89	21	22	17	F10	31	40	61
8	200	62	152	267	345	188	214	215	101	23	25	19	F12	44	62	99
10	250	70	165	326	405	236	254	260	104	26	28	22	F12	68	97	139
12	300	81	178	375	485	281	298	290	129	31	35	27	F14	102	142	218
14	350	92	190	416	535	320	328	320	134	36	42	32	F14	143	202	282
16	400	102	216	480	595	371	377	370	158	40	50	36	F16	216	302	381
18	450	114	222	534	635	420	402	395	158	40	50	36	F16	288	381	458
20	500	127	229	588	700	469	437	430	168	50	60	46	F16	377	533	580
24	600	154	267	692	815	549	492	480	240	90	65	18*12	F25	606	833	893
28	700	165	292	800	927	655	570	555	245	95	75	20*12	F25	848	1157	1398
30	750	190	318	857	984	698	605	600	300	100	85	25*14	F30	1124	1366	1748
32	800	190	318	910	1060	755	630	625	310	110	90	25*14	F30	1215	1692	2024
36	900	203	330	1000	1168	870	690	665	320	120	100	28*16	F30	1470	2112	2615
40	1000	216	410	1115	1289	943	768	765	360	130	115	32*18	F35	2063	2681	3468
44	1100	254	410	1220	1403	1045	818	815	360	130	115	32*18	F35	2586	3362	4539
48	1200	254	470	1330	1510	1145	884	880	360	130	125	36*20	F35	3084	3933	5194

## 300LB

SIZE		L	L1	D	D1	d	H1	H2	H3	S1	d1	S	ISO	Weight (lbs)		
in	mm													Wafer	Lug	Flange
2	50	45	-	95	-	46	118	128	86	18	18	14	F10	13.2	17.6	-
2.5	65	48	-	112	-	61	126	136	86	18	18	14	F10	15.4	19.8	-
3	80	48	114	126	190	76	134	140	86	18	18	14	F10	17.6	22.3	30.9
4	100	54	127	155	230	96	144	150	86	18	18	14	F10	19.8	28.7	41.9
5	125	57	-	184	-	118	178	170	89	21	22	17	F10	26.5	39.7	-
6	150	59	140	224	318	143	199	200	101	23	25	19	F12	39.7	57.3	92.6
8	200	73	152	280	381	188	234	240	104	26	28	22	F12	61.7	94.8	149.9
10	250	83	165	345	445	236	278	260	129	31	35	27	F14	114.6	156.5	209.4
12	300	92	178	395	521	281	318	310	134	36	42	32	F14	158.7	224.8	328.5
14	350	117	190	440	585	320	367	360	158	40	50	36	F16	231.5	354.9	421.1
16	400	133	216	495	648	371	392	385	168	50	60	46	F16	326.3	480.6	573.2
18	450	149	222	560	712	420	437	425	240	90	65	18*12	F25	471.8	696.7	908.3
20	500	159	229	622	775	469	465	450	245	95	75	20*12	F25	597.5	870.8	1159.6
24	600	181	267	720	915	549	530	530	310	110	90	25*14	F30	952.4	1417.6	1785.7



# Dimensional Data for ISO Actuator Mounting

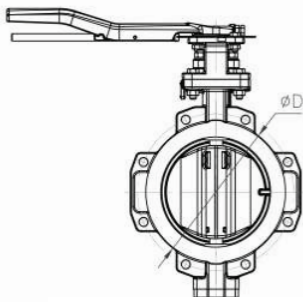

Lug Type BL631  
BL731

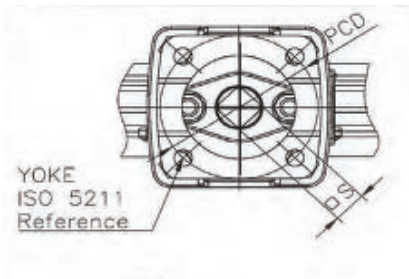

YOKE  
ISO 5211  
Reference

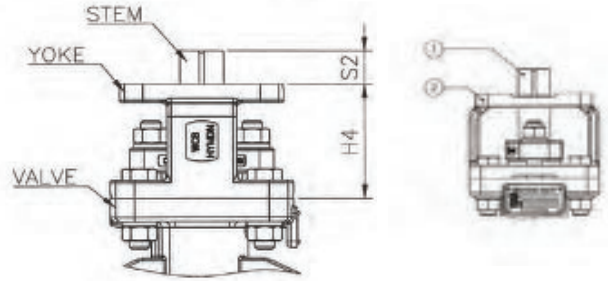

150 LB  
DN50-DN1200

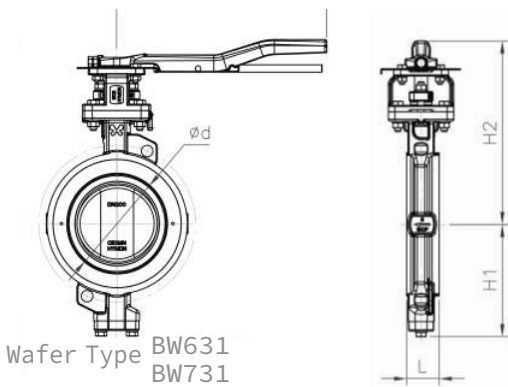

Wafer Type BW631  
BW731

SIZE		H4	S2	Yoke		Valve
mm	in			ISO	PCD	ISO
50	2	70	16	F07	70	F10
65	2.5	70	16	F07	70	F10
80	3	70	16	F07	70	F10
100	4	70	16	F07	70	F10
125	5	70	19	F07	70	F10
150	6	70	19	F07	70	F10
200	8	80	21	F10	102	F12
250	10	80	24	F10	102	F12
300	12	100	29	F12	125	F14
350	14	100	34	F12	125	F14
400	16	120	38	F14	140	F16
450	18	120	38	F14	140	F16
500	20	120	48	F14	140	F16
600	24	150	90	F16	165	F25
700	28	150	96	F16	165	F25
750	30	200	100	F25	254	F30
800	32	200	110	F25	254	F30
900	36	200	120	F25	254	F30
1000	40	230	130	F30	298	F35
1100	44	230	130	F30	298	F35
1200	48	230	130	F30	298	F35

## TORQUE CHARTS

ANSI Class 150 LB Models BW631/BL631

in	mm	SOFT SEAT BAR/PSI						FIRE SAFE SEAT BAR/PSI					
		Δ P 6BAR		Δ P 10BAR		Δ P 16BAR		Δ P 6BAR		Δ P 10BAR		Δ P 16BAR	
		Nm	in Lbs	Nm	in Lbs	Nm	in Lbs	Nm	in Lbs	Nm	in Lbs	Nm	in Lbs
2	50	16	142	20	177	24	212	23	204	26	230	29	257
2.5	65	18	159	21	186	26	230	27	239	35	310	38	336
3	80	21	186	27	239	32	283	32	283	38	336	47	416
4	100	26	230	31	274	41	363	44	389	52	460	61	540
5	125	32	283	47	416	69	611	62	549	77	682	100	885
6	150	45	398	62	549	93	823	83	735	103	912	135	1195
8	200	74	655	115	1018	175	1549	152	1345	182	1611	202	1788
10	250	117	1036	183	1620	281	2487	237	2098	272	2407	321	2841
12	300	189	1673	290	2567	441	3903	357	3160	411	3638	487	4310
14	350	284	2514	430	3806	583	5160	506	4478	587	5195	696	6160
16	400	417	3691	629	5567	852	7541	705	6240	827	7320	990	8762
18	450	522	4620	804	7116	1105	9780	906	8019	1070	9470	1289	11409
20	500	788	6974	1185	10488	1601	14170	1266	11205	1497	13250	1809	16011
24	600	1242	10993	1851	16383	2486	22003	1901	16825	2259	19994	2736	24216

ANSI Class 300 LB Models BW731/BL731

in	mm	SOFT SEAT BAR/PSI						FIRE SAFE SEAT BAR/PSI					
		Δ P 20BAR		Δ P 30BAR		Δ P 40BAR		Δ P 20BAR		Δ P 30BAR		Δ P 40BAR	
		Nm	in Lbs	Nm	in Lbs	Nm	in Lbs	Nm	in Lbs	Nm	in Lbs	Nm	in Lbs
2	50	28	248	36	319	44	389	33	292	39	345	46	407
3	60	31	274	40	354	49	434	40	354	49	434	58	513
3	80	36	319	46	407	57	504	56	496	66	584	77	682
4	100	60	531	83	735	105	929	93	832	115	1018	137	1213
5	125	104	920	142	1257	179	1584	153	1354	190	1682	228	2018
6	150	152	1345	206	1823	261	2310	219	1938	274	2425	328	2903
8	200	462	4089	642	5682	822	7275	653	5780	833	7373	1014	8975
10	250	726	6426	1001	8860	1276	11294	995	8806	1269	11232	1544	13666
12	300	1075	9515	1474	13046	1874	16586	1430	12657	1829	16188	2228	19719
14	350	1676	14834	2276	20144	2875	25446	2138	18923	2737	24225	3337	29535
16	400	2278	20162	3112	27544	3947	34934	2892	25596	3727	32987	4562	40377
18	450	3131	27712	4266	37757	5401	47803	3897	34491	5031	44528	6166	54574
20	500	4871	43112	6625	58636	8378	74152	5924	52432	7678	71107	9430	83463
24	600	6606	58468	8984	79515	11362	100562	8034	71107	10412	92154	12789	113192

1. All above valve torques are sized as wet service, defined as lubricated clean and nonabrasive line medias. Torques contain a safety factor of 20%.

2. Installing seats in the upstream direction will result in lower torques and better life cycles.

# Flow Coefficients & Technical Data

## Cv FLOW COEFFICIENT

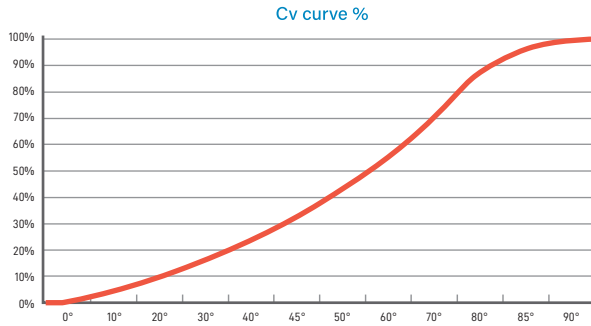

## 150LB

SIZE		Cv Value										
mm	in	10°	20°	30°	40°	45°	50°	60°	70°	80°	85°	90°
50	2	0	8	22	36	44	51	60	69	72	70	70
65	2.5	2	16	38	61	71	83	109	135	146	152	150
80	3	6	33	62	94	108	118	143	176	208	230	227
100	4	16	58	106	155	178	213	274	349	433	465	473
125	5	20	94	167	230	263	310	391	488	561	604	605
150	6	40	147	242	335	382	422	560	729	925	975	1010
200	8	66	237	368	509	606	712	985	1296	1640	1715	2004
250	10	139	390	595	807	963	1168	1606	2134	2814	3180	3199
300	12	204	548	820	1138	1357	1591	2219	3067	4085	4484	4672
350	14	264	674	972	1386	1658	1994	2840	3925	5164	5828	5947
400	16	384	864	1196	1765	2155	2611	3755	5105	6975	7920	8182
450	18	508	1092	1551	2341	2881	3522	5125	7134	9511	10599	11548
500	20	626	1294	1792	2651	3304	4082	5919	8256	11429	13126	13813
600	24	1047	2251	3178	4563	5543	6568	9277	12932	17093	18328	19021

## Cv FLOW COEFFICIENT FOR METAL SEATED VALVES

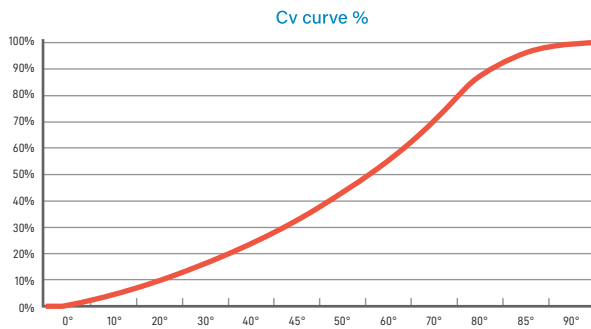

## 300LB

SIZE		Cv Value										
mm	in	10°	20°	30°	40°	45°	50°	60°	70°	80°	85°	90°
80	3	6	33	62	94	108	118	143	176	208	230	227
100	4	16	58	106	155	178	213	274	349	433	465	473
125	5	20	94	167	230	263	310	391	488	561	604	605
150	6	37	137	225	312	355	393	521	678	860	907	939
200	8	62	220	343	473	563	662	916	1206	1525	1595	1864
250	10	129	362	554	750	896	1087	1493	1985	2617	2957	2975
300	12	190	510	762	1059	1262	1480	2064	2852	3799	4170	4345
350	14	246	627	904	1289	1542	1854	2641	3650	4803	5420	5531
400	16	357	803	1112	1642	2004	2428	3492	4748	6487	7365	7609
450	18	473	1015	1442	2177	2679	3275	4766	6634	8845	9857	10739
500	20	583	1204	1667	2466	3073	3797	5504	7678	10629	12207	12846
600	24	974	2093	2956	4244	5155	6108	8627	12027	15897	17045	17689

Temperature		Class 150				Class 300			
		PTFE		RPTFE		PTFE		RPTFE	
°F	°C	psig	bar	psig	bar	psig	bar	psig	bar
-20 to 100	-29 to 38	285	19.7	285	19.7	740	51	740	51
150	66	273	18.8	273	18.8	708	48.8	708	48.8
200	93	260	17.9	260	17.9	550	37.9	675	46.3
250	121	245	16.9	245	16.9	425	29.3	530	36.5
300	149	230	15.9	230	15.9	300	20.7	390	26.9
350	177	140	9.7	215	14.8	175	12.1	250	17.2
400	204	50	3.4	100	6.9	50	3.4	100	6.9



**Upgrade Your Valve with these Easy to Install Repair Kits.**



STATE OF THE ART UNIQUE DESIGN

3 VALVES IN ONE

OUR STANDARD SOFT SEATED VALVE CAN BE UPGRADED TO INCONEL METAL SEATED VALVE OR FIRE SAFE DESIGN.

## PRESSURE-TEMPERATURE RATING FOR SOFT SEATS AND METAL SEATS

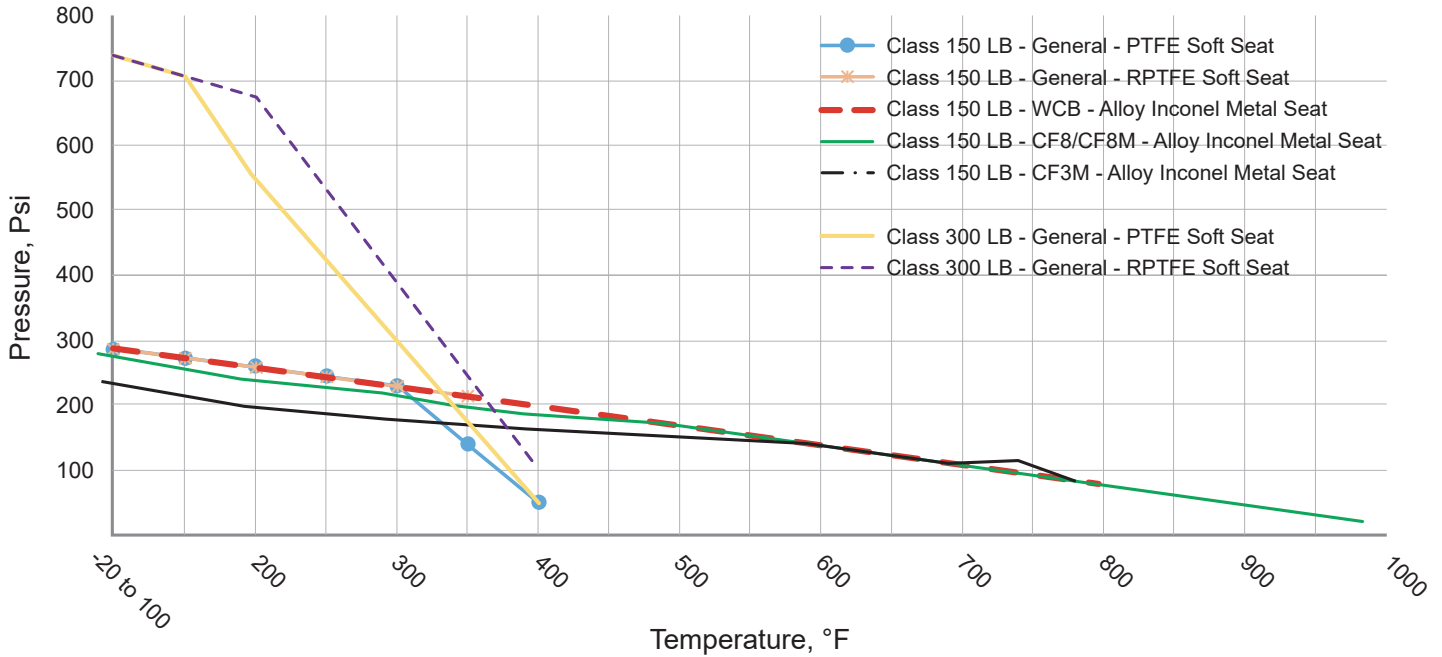

Body and Seat Temperature		Class 150										Class 300			
		General (a)				WCB		CF8/CF8M		CF3M		General (a)			
		PTFE		RPTFE		AMS 5596 Alloy Inconel (b)								PTFE	
°F	°C	psig	bar	psig	bar	psig	bar	psig	bar	psig	bar	psig	bar	psig	bar
20 to 100	29 to 38	285	197	285	197	285	197	275	189	230	159	740	51	740	51
150	66	273	188	273	188	273	188	265	176	313	147	708	78.8	708	58.8
200	93	260	179	260	179	260	179	235	162	195	134	550	37.9	675	46.5
250	121	245	169	245	169	245	169	225	155	185	128	425	29.3	530	36.5
300	149	230	159	230	159	230	159	215	149	175	121	300	20.7	300	26.9
350	177	140	97	215	148	215	148	195	134	168	116	175	12.1	250	17.2
400	204	50	34	100	69	200	138	183	126	150	110	80	3.4	100	6.9
500	260			(c)	(c)	170	117	170	117	150	103			(c)	(c)
600	316					140	97	140	97	140	97				
650	343					125	86	125	86	125	86				
700	371					110	76	110	76	110	76				
750	390					95	66	96	66	110	76				
800	427					80	55	80	55	80	55				
850	454					(d)	(d)	66	45	(c)	(c)				
900	482					(d)	(d)	50	34						
950	510					(d)	(d)	35	24						
1000	538					(d)	(d)	20 (f)	14 (f)						

(a) General carbon steel and stainless steel

(b) AMS 5596 Inconel represents Aerospace Material Specification level Inconel 718

(c) RPTFE covers instantaneous 500°F depends on working condition

(s) Above 800°F the carbide phase of WCB might be transed to graphite. Workable but not suggested

(e) Shall not be used over 800°F

(f) From 1000°F, shall only use CF8/CF8M with carbon content equals/greater than 0.04%. For temperature range between 1000°F to 1500°F, contact engineering sales for further details.

*Special descriptions, dimensions and construction details illustrated may vary slight from this bulletin. They are for general use only. We reserve the right to revise or modify product design without prior notice.*



YOUR ONE-STOP-SHOP FOR ALL YOUR BUTTERFLY VALVES and ACTUATION

*Butterfly Valve Packages shipping Daily*

**Resilient Seated, DI Valves, PFA lined, AWWA Valves, High Performance, Double Offset, Triple Offset...**

